

SolShare 2

Installation manual

For Australia and New Zealand



1030-SolShare2InstallationManual-ANZ

For SolShare 2 model number SOLSHARE-2.0-ANZ.

Always use the most up-to-date version of this document, available at <https://hubs.li/Q03YQgwP0>.



Version	Date released	Updates
A23	07/05/2026	
B02	17/06/2026	Updated Wi-Fi connection information.

© 2026 – Allume Energy Pty Ltd – All rights reserved.

This manual accompanies Allume Energy Pty Ltd equipment for use by authorised end users. It contains proprietary information intended solely to support the correct and safe installation and operation of the equipment.

The technical instructions and illustrations contained in this manual are the property of Allume Energy Pty Ltd. This information and the illustrations are to be treated as confidential and may not be reproduced, disclosed or distributed, in any form or by any means, without the prior written consent of Allume Energy Pty Ltd. End users may use, disclose or communicate any information or illustrations contained within this manual to the extent necessary for the correct installation, usage and operation of the equipment.

Allume Energy Pty Ltd reserves the right to make changes to all information, technical instructions, illustrations and specifications contained in this manual, at any time and without prior notice.

Nothing in this manual should be construed as a warranty, guarantee or legal obligation on the part of Allume Energy Pty Ltd. You rely on the contents of this manual at your own risk. To the extent permitted by law, Allume Energy Pty Ltd excludes any warranties, guarantees or representations that any information contained in this manual is accurate, reliable, current, complete or suitable for any particular purpose, and any liability for any loss or damage (whether arising from negligence or otherwise and whether foreseeable or not), relating to (directly or indirectly), any information, technical instructions, illustrations or specifications contained in this manual. To the extent that any such liability cannot be excluded by law but can be limited, Allume Energy Pty Ltd's liability is limited to the extent permitted by law.



Contents

1. Language and symbols	6
1.1. Definitions	7
2. Introduction	8
2.1. Welcome	8
2.2. Important information	8
3. About SolShare	9
3.1. How does SolShare work?	9
3.2. SolShare features	11
4. Installation preparation	15
4.1. Required information	15
4.2. Required supplies	15
4.3. Additional supplies, if needed	17
4.4. Specific tools	17
4.5. Installation site requirements	18
5. Mounting SolShare	19
6. Opening installation cover	22
7. AC electrical connections	23
7.1. Maintenance isolator box	23
7.2. At SolShare	24
7.3. At switchboard	27
7.4. Compliance with emergency backstop mechanisms (EBMs)	28
8. Current transformers	29
8.1. At SolShare	30
8.2. At switchboard	31
8.3. Extending CT cables	32
9. Internet and communications	33
9.1. Ethernet	33
9.2. Wi-Fi	34
10. Closing installation cover	35
11. Site labelling and documentation	36



12. Commissioning	37
12.1. Pre-commissioning checks	37
12.2. Commissioning	37
12.3. Post-commissioning checks	40
13. Startup and shutdown	41
13.1. Startup procedure	41
13.2. Shutdown procedure	42
14. Maintenance	43
Appendix A: Technical information	44
Appendix B: Status LED states	45

Figures

Figure 3-1: Example installation of SolShare	9
Figure 3-2: SolShare installation steps	10
Figure 3-3: SolShare internet and communications	10
Figure 3-4: SolShare dimensions and features	12
Figure 3-5: Cable connections within SolShare	13
Figure 3-6: Recommended cable entry configuration where all 15 single-phase tenancy connections are used	13
Figure 3-7: Recommendations for cable labelling	14
Figure 4-1: Installation site requirements	18
Figure 5-1: SolShare handles and recommended lift points	20
Figure 7-1: AC electrical connections between SolShare and switchboard	23
Figure 8-1: CT connections between SolShare and switchboard	29
Figure 8-2: Extending CT cables	32
Figure 13-1: Typical location of switches and isolators used in SolShare's startup procedure	41
Figure 13-2: Typical location of isolators typically used in SolShare's shutdown procedure	42





Tables

Table 1: Required information for a SolShare installation	15
Table 2: Required supplies for a SolShare installation (table continued on next page)	15
Table 3: Additional supplies for a SolShare installation	17
Table 4: Specific tools for a SolShare installation	17

















1. Language and symbols

The following safety symbols are used in this document. Familiarise yourself with the symbols and their meaning before installing or operating SolShare:

	WARNING
Indicates a potential hazard that if ignored, could result in death or serious injury.	
	CAUTION
Indicates a potential hazard that if ignored, could result in minor or moderate injury.	
	NOTICE
Indicates additional information, emphasised content or tips that may be helpful to avoid potential property damage or equipment malfunction.	
	TIP
Indicates helpful information for the installation and/or operation of SolShare.	

The following symbols are used on equipment markings and throughout this manual:

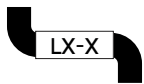
Symbol	Description	Symbol	Description
	Electric shock hazard		Two-person lift
	Regulatory Compliance Mark (Australia)		Inspect product
	Refer to accompanying installation manual (this document)		CE mark (Europe)
	Earth		Protective earth
	Ethernet		Wi-Fi
	Internet/network LED		SolShare status LED
	Hex head		Flat head
	Torque		Cable labelling reminder

1.1. Definitions

Acronym	Definition
AS/NZS	Australian/New Zealand standard
CT	Current transformer
DNSP	Distribution network service provider
EBM	Emergency backstop mechanism
IP	Ingress protection
LED	Light-emitting diode
POC	Point of connection
RCBO	Residual current breaker with overcurrent protection
RCD	Residual current device
RCM	Residual current monitoring
SDI	Single double insulated (cable)
SLD	Single line diagram
4C+E	Four core and earth (cable)



2. Introduction

2.1. Welcome

Thank you for helping us unlock solar for apartments. We're glad you're here.

This manual is designed to guide you through a smooth SolShare installation, from unboxing to commissioning, so you can focus on what you do best: delivering safe, reliable solar for your customers.

If you need extra support, our technical support team is available on:

☎ +61 3 7038 0686

✉ support@allumeenergy.com.au

We appreciate the expertise you bring to every project. Let's get started!

2.2. Important information



WARNING

Risk of injury or death

The protection provided by SolShare may be impaired if SolShare is used in a manner not specified in this manual. Always follow instructions in this manual.



WARNING

Risk of electric shock from live components

SolShare installation must be performed by a qualified electrician with all relevant certifications and qualifications required in the installation location.

Electrician must complete Allume installation training course prior to commencing installation.



NOTICE

Standards and regulations

All SolShare installations must be carried out in accordance with all relevant standards and regulations in the installation location.



NOTICE

Project single line diagram

Typical and recommended configurations of SolShare have been shown throughout this manual. Always follow your installation's project-specific single line diagram (SLD).

Always use the most up-to-date version of this document, available at <https://hubs.li/Q03YQgwP0>.



3. About SolShare

3.1. How does SolShare work?

SolShare is a world-first technology, which splits electricity from a single rooftop solar system and shares it between multiple dwellings.

The behind-the-meter solution typically requires no change to existing electrical infrastructure.

Its configuration is flexible, enabling your customers to choose how solar is most fairly shared.

3.1.1 Example SolShare Installation

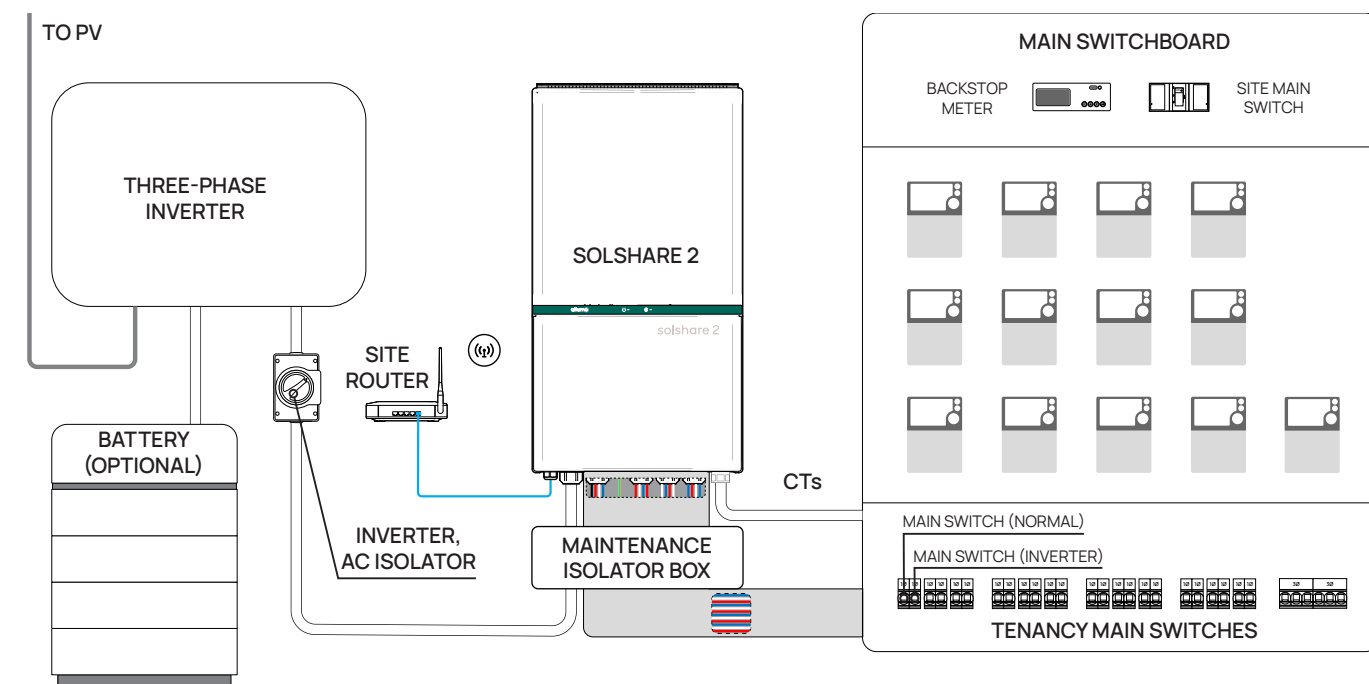

Figure 3-1: Example installation of SolShare



3.1.2 SolShare installation steps

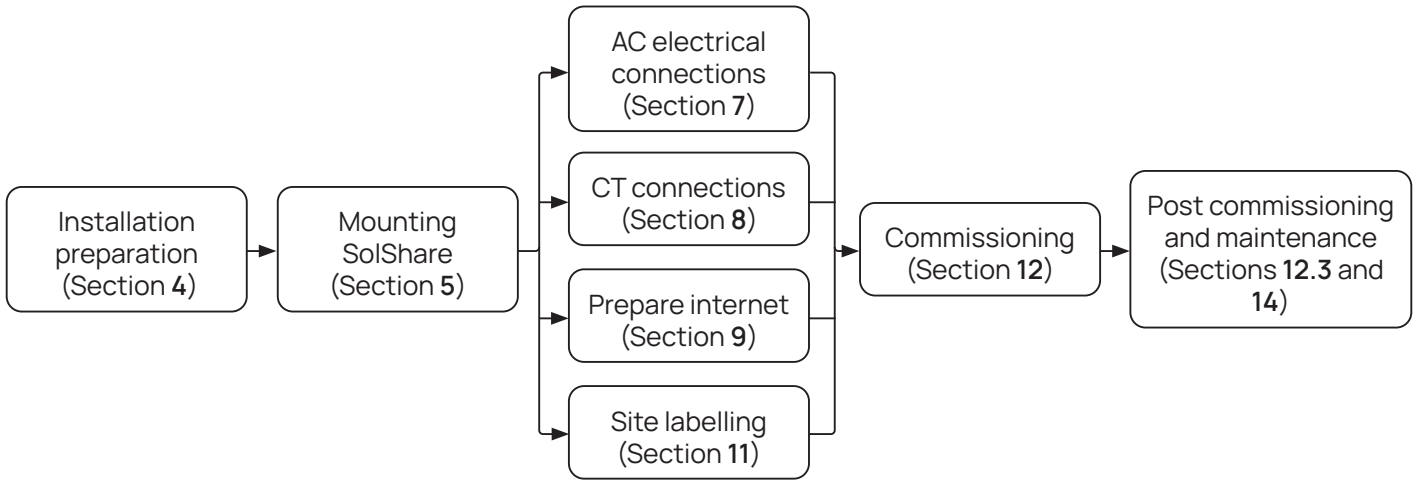

Figure 3-2: SolShare installation steps

3.1.3 SolShare internet connectivity

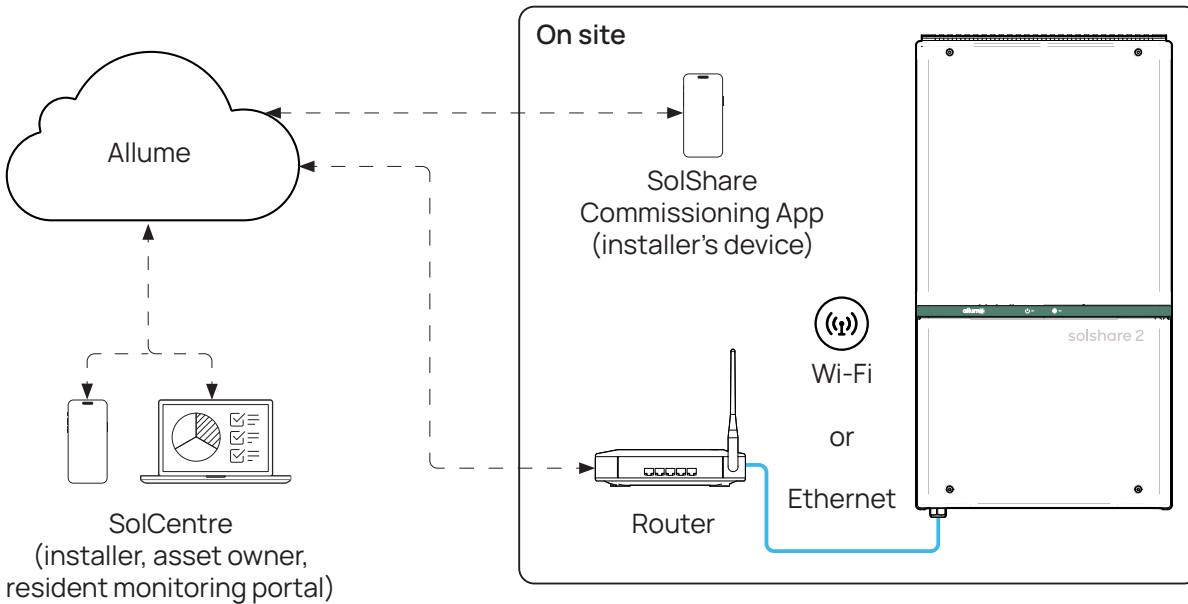
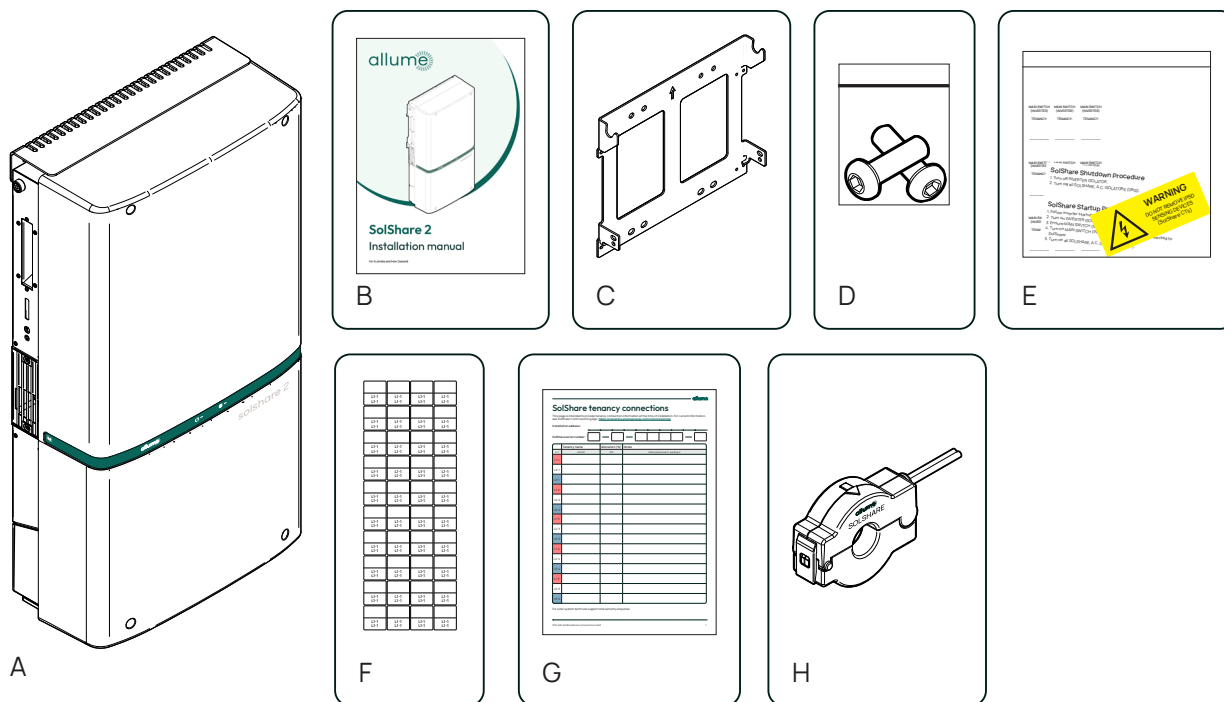

Figure 3-3: SolShare internet and communications

3.2. SolShare features

3.2.1 What's in the box



Item	Name	Quantity
A	SolShare 2	1
Installation kit		
B	Installation manual	1
C	Wall mount bracket	1
D	Wall mount locking screws M6x16mm (2)	1
E	Label pack	1
F	Cable labels	1 sheet
G	SolShare tenancy connections page	1
SolShare current transformers box		
H	SolShare current transformers (CTs)	15



NOTICE Visual check

Inspect all components provided with SolShare for damage before proceeding.



3.2.2 SolShare overview

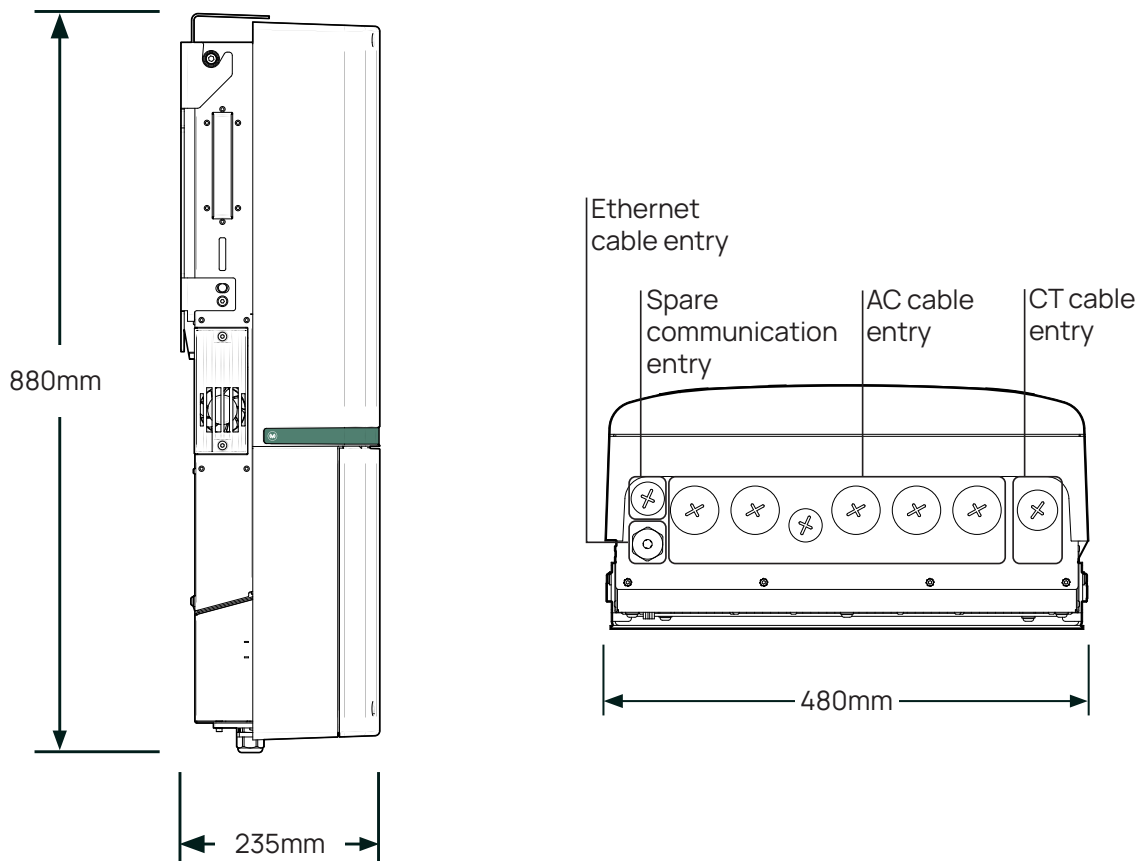
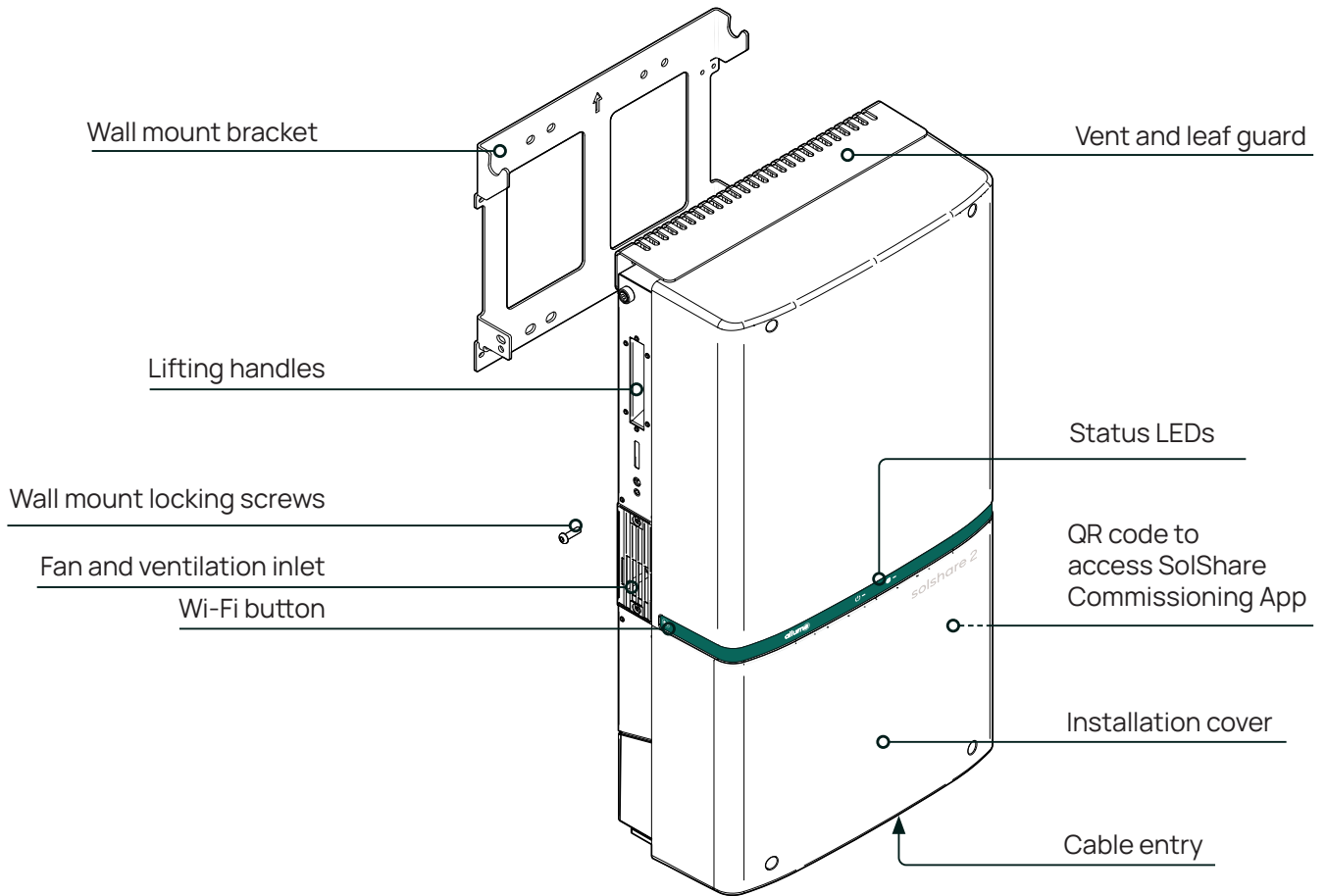

Figure 3-4: SolShare dimensions and features

3.2.3 Cable connections within SolShare

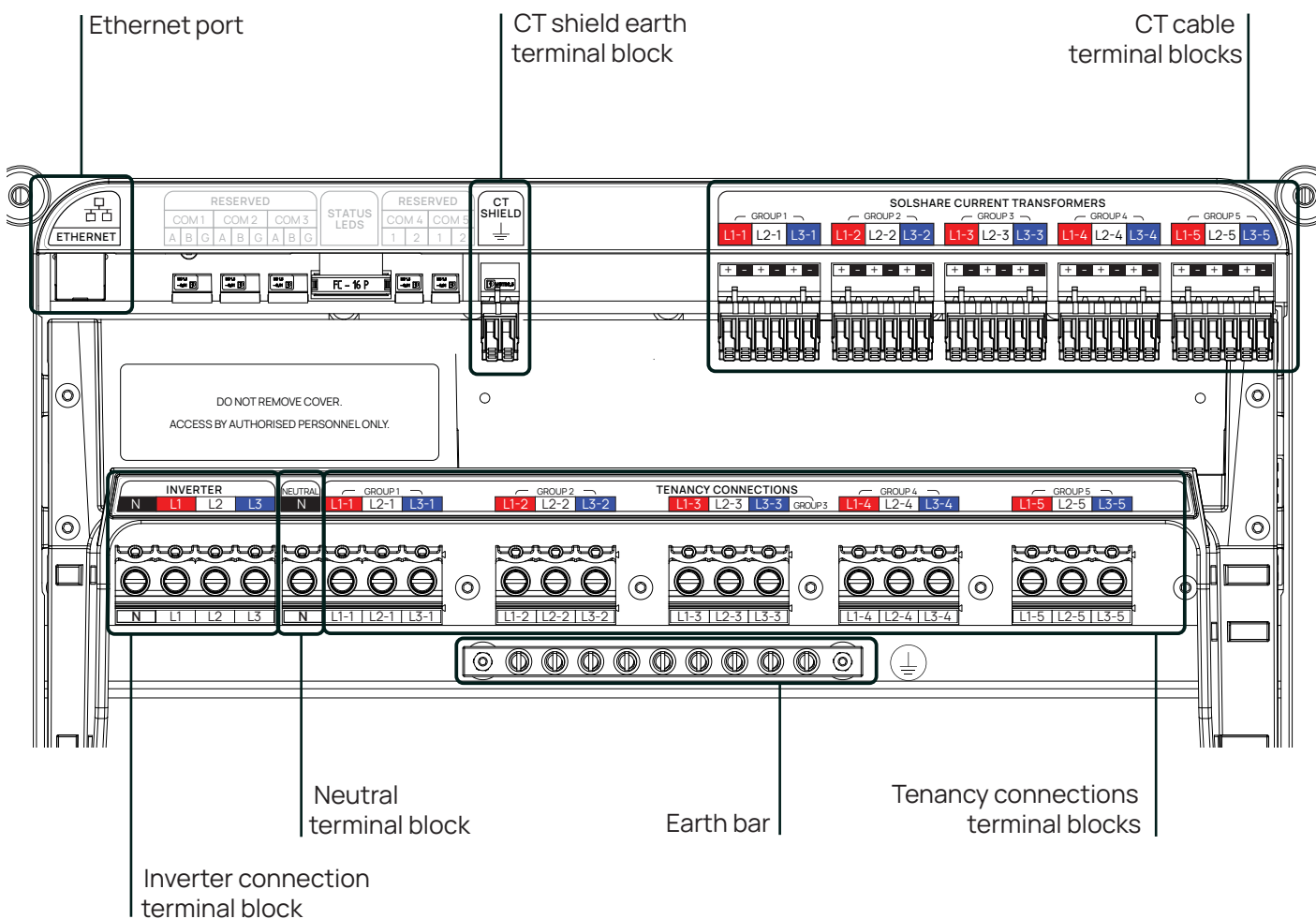

Figure 3-5: Cable connections within SolShare

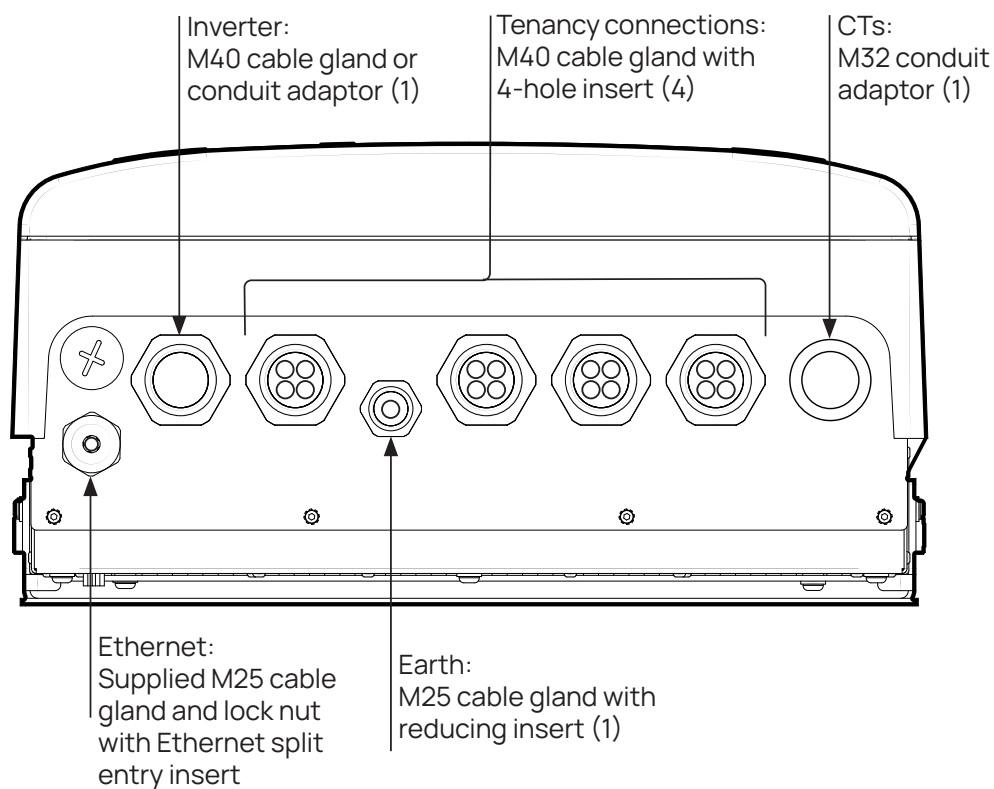

Figure 3-6: Recommended cable entry configuration where all 15 single-phase tenancy connections are used



3.2.4 Cable labelling



TIP
Cable labelling

Each SolShare may provide solar to up to 15 tenancies. All cables should be labelled correctly for effective troubleshooting and servicing of SolShare. Cable labels are provided with each SolShare.



TIP
Labelling symbol

This icon is used throughout this document as a reminder to label cables.

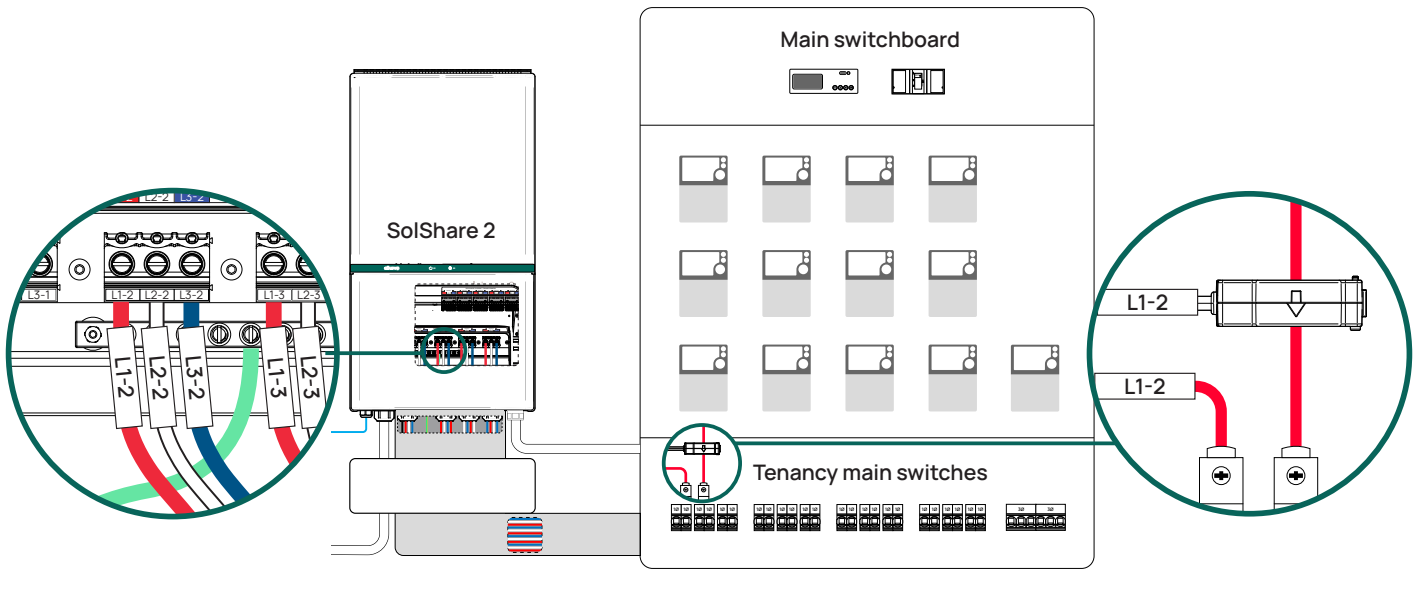

Figure 3-7: Recommendations for cable labelling

4. Installation preparation

4.1. Required information

Information	Reference section
<input type="checkbox"/> Project SLD	Throughout - including Sections 7 and 8
<input type="checkbox"/> Completed SolShare tenancy connections page	Section 7 Section 8 Section 11 Section 12.2
<input type="checkbox"/> Site Wi-Fi details (if applicable)	Section 9.2 Section 12.2.2
<input type="checkbox"/> SolShare Commissioning App login	Section 12.2
<input type="checkbox"/> Allume training number	Section 12.2
<input type="checkbox"/> Installation warranty contact details	Section 12.2

Table 1: Required information for a SolShare installation

4.2. Required supplies

Sizes and quantities to be specified to requirements of installation.

Item	Equipment	Qty	SolShare considerations	Reference
<input type="checkbox"/> Wall mount bracket fixings				
	Fixings for wall mount bracket	4 min	<ul style="list-style-type: none"> Type: Suitable for installation location (see Section 4.5) Max diameter: <ul style="list-style-type: none"> Masonry: 10mm bolt, max head height: 13mm Timber/racking: 6mm (1/4") Minimum shear load rating per fixing: 40kg 	Section 5
<input type="checkbox"/> Cable				
	Earth cable	As needed	<ul style="list-style-type: none"> Min cable size: Per local wiring regulations Terminal capacity (max): 16mm² 	Section 7.2
	Inverter cable	As needed	<ul style="list-style-type: none"> Recommended type: 4C+E recommended Min cable size: Per local wiring regulations Terminal capacity (max): 16mm² 	
	Tenancy connections cable	As needed	<ul style="list-style-type: none"> Recommended type: SDI (single phase tenancies) or multi-core (three-phase tenancies) Min cable size: Rated for total maximum per-phase generation capacity of inverter/s connected to this SolShare Terminal capacity (max): 16mm² 	

Table 2: Required supplies for a SolShare installation (table continued on next page)



Item	Equipment	Qty	SolShare considerations	Reference
<input type="checkbox"/> Cable entry glands, adaptors & inserts				
	Inverter:	1	<ul style="list-style-type: none"> IP65 SolShare rating must be maintained for performance and warranty purposes (inclusive of dust, and water). Any unused holes must be sealed with the provided cable entry plugs, or other suitable means. 	Section 7.2
	Tenancy connections:	As needed 1 MIN, 4 MAX		
	Earth:	1		
	Current transformers:	1	<ul style="list-style-type: none"> SolShare cable entry plate thickness: 3mm ITEMS SUPPLIED WITH SOLSHARE: <ul style="list-style-type: none"> M40 (5), M32 (1), M25 (2) cable entry plugs M25 (1) cable gland & locknut with Ethernet split entry insert 	Section 8.1
	Sealing pins, plugs or solid inserts to seal unused holes	As needed		
<input type="checkbox"/> Maintenance isolator box				
	INVERTER ISOLATOR	1	<ul style="list-style-type: none"> Three-phase 	Section 7.1
	SOLSHARE, AC ISOLATORS (GRID)	1 per tenancy connection	<ul style="list-style-type: none"> Single phase or three-phase per tenancy to suit number of tenancy's phases connected to SolShare Rated for maximum per phase output of the inverter 	
	Enclosure	1	<ul style="list-style-type: none"> Typically used to house SOLSHARE, AC ISOLATORS (GRID) and INVERTER ISOLATOR 	
<input type="checkbox"/> MAIN SWITCH (INVERTER) per SolShare tenancy connection				
	MAIN SWITCHES (INVERTER)	1 per tenancy connected to SolShare	<ul style="list-style-type: none"> Single phase or three-phase per tenancy to suit number of tenancy's phases connected to SolShare Rated for maximum per phase output of the inverter 	Section 7.3
<input type="checkbox"/> Internet				
	Router	1	<ul style="list-style-type: none"> IPv4 Data requirement: typically < 250MB / month / SolShare If using Wi-Fi: <ul style="list-style-type: none"> 2.4GHz 802.11 b/g/n WPA2 encryption 	Section 9
	Ethernet cable (if used)	As needed	<ul style="list-style-type: none"> Type: Ethernet cable (e.g., Cat5e/6/6a) with RJ45 connector 	Section 9.1
<input type="checkbox"/> Installation labels				
	Installation labels for site compliance	As needed	<ul style="list-style-type: none"> Some labels supplied with SolShare 	Section 11

Table 2: Required supplies for a SolShare installation

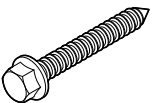
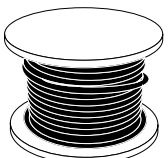
4.3. Additional supplies, if needed

Item	Equipment	Qty	SolShare considerations	Reference
<input type="checkbox"/> CT cable extension				
	CT extension cables	As needed	<ul style="list-style-type: none"> Type: Shielded, twisted pair (shielded CAT6 or instrumentation cable recommended) Min gauge: 0.25mm² Max gauge: 2.5mm² Max length: 100m per CT (including cable provided with CT) 	Section 8.3
	CT extension grounding cable	As needed	<ul style="list-style-type: none"> Min gauge: 0.25mm² Max gauge: 2.5mm² 	
	CT extension and CT extension shielding connectors	As needed	<ul style="list-style-type: none"> Type: Splicing connector or pluggable terminal block Recommended type: Wago 221 	
<input type="checkbox"/> SolShare padlock				
	Padlock	1	<ul style="list-style-type: none"> Max diameter of shackle: 7mm 	Section 5

Table 3: Additional supplies for a SolShare installation

4.4. Specific tools

Tool	Description	Reference section
	4mm hex key	Section 5 Section 6 Section 10
	Torque wrench capable of: <ul style="list-style-type: none"> 4Nm with 4mm hex head 1.5Nm with 4mm hex head 1.2Nm with flat head 	Section 5 Section 10 Section 7.2
	Flat head screwdriver	Section 7.2
	Internet-connected device (tablet, phone, laptop, etc.) Access SolShare Commissioning App: solcentre.allumeenergy.com/commissioning	Section 12.2

Table 4: Specific tools for a SolShare installation



4.5. Installation site requirements

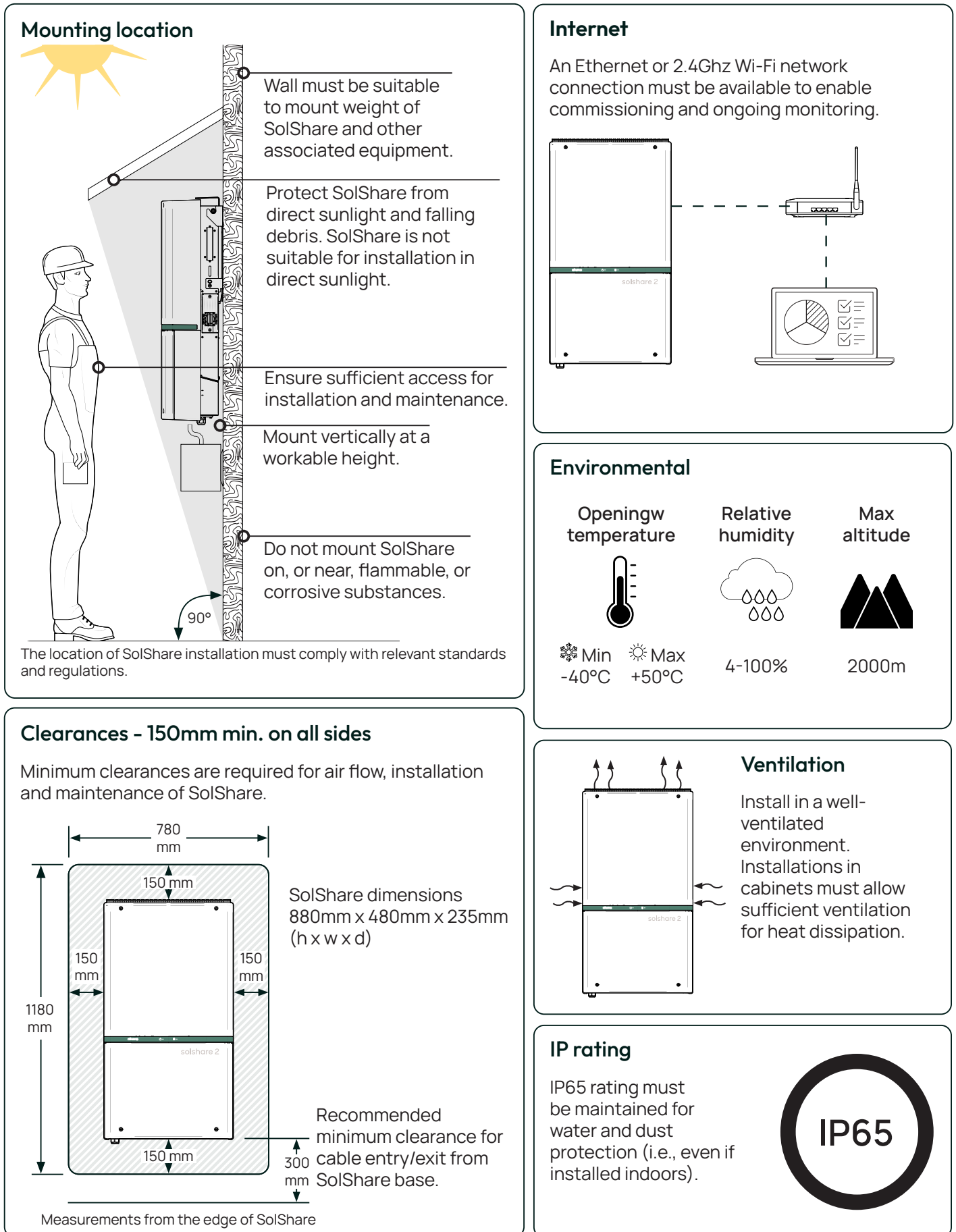

Figure 4-1: Installation site requirements

5. Mounting SolShare

- 1 Attach the wall mount bracket to a suitable wall (see Section 4.5 for installation location requirements), using fixings as specified in Table 2.

i NOTICE
Fixings

Use at least four fixings, with at least one fixing in each quadrant. Each fixing must be rated for at least 40kg shear loading for wall material.

Ensure protrusion of fixings does not exceed 13mm from wall plate.

Important dimensions:

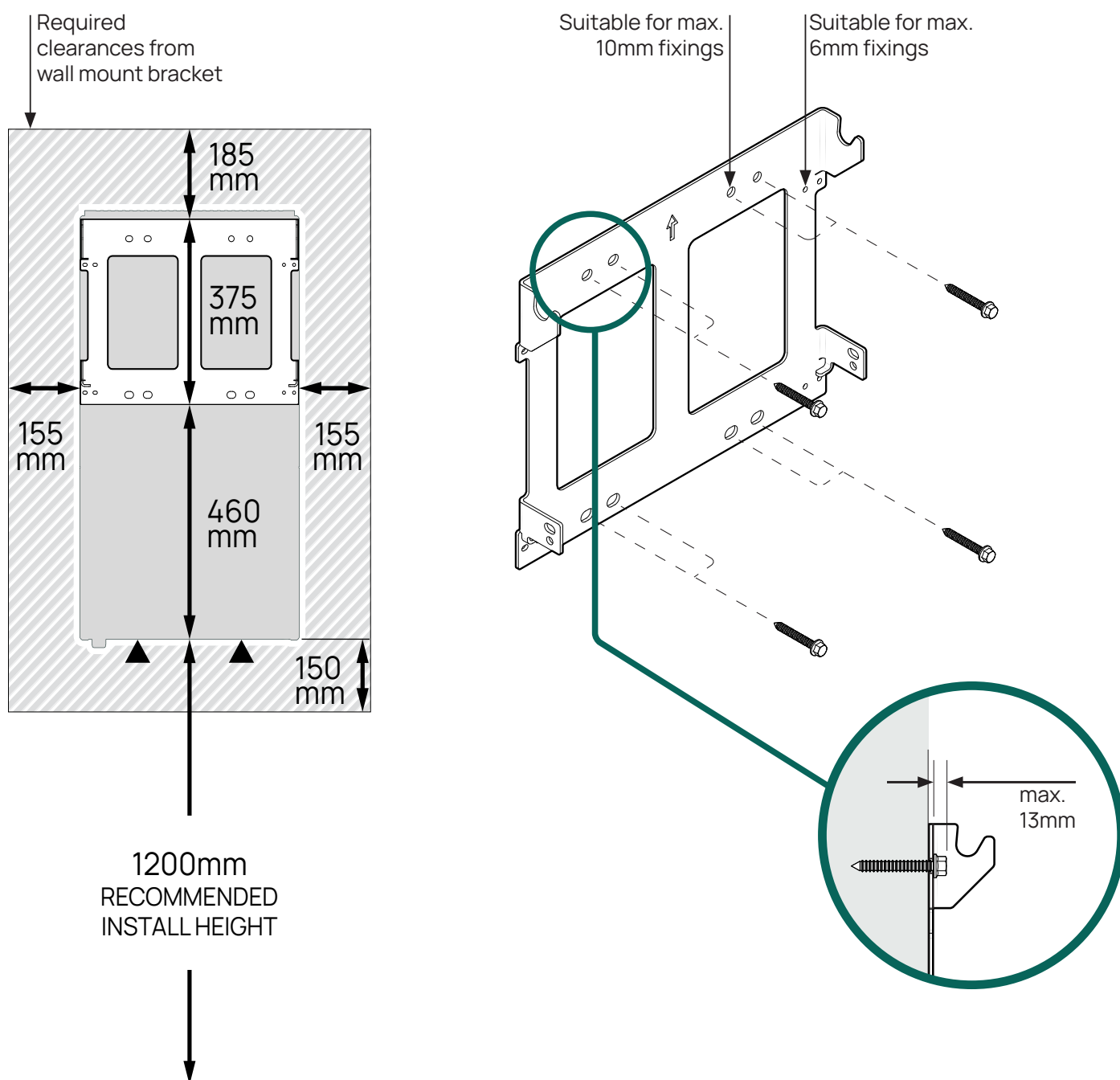



2 Remove SolShare from packaging box and prepare to lift.



CAUTION
Risk of injury from heavy object

SolShare weighs 41kg. Lifting SolShare in an inappropriate manner may lead to injury.

Always lift SolShare with a two-person lift and/or a mechanical aid.



NOTICE
Cable gland damage

Resting SolShare on its bottom base may cause damage to the supplied Ethernet cable gland.

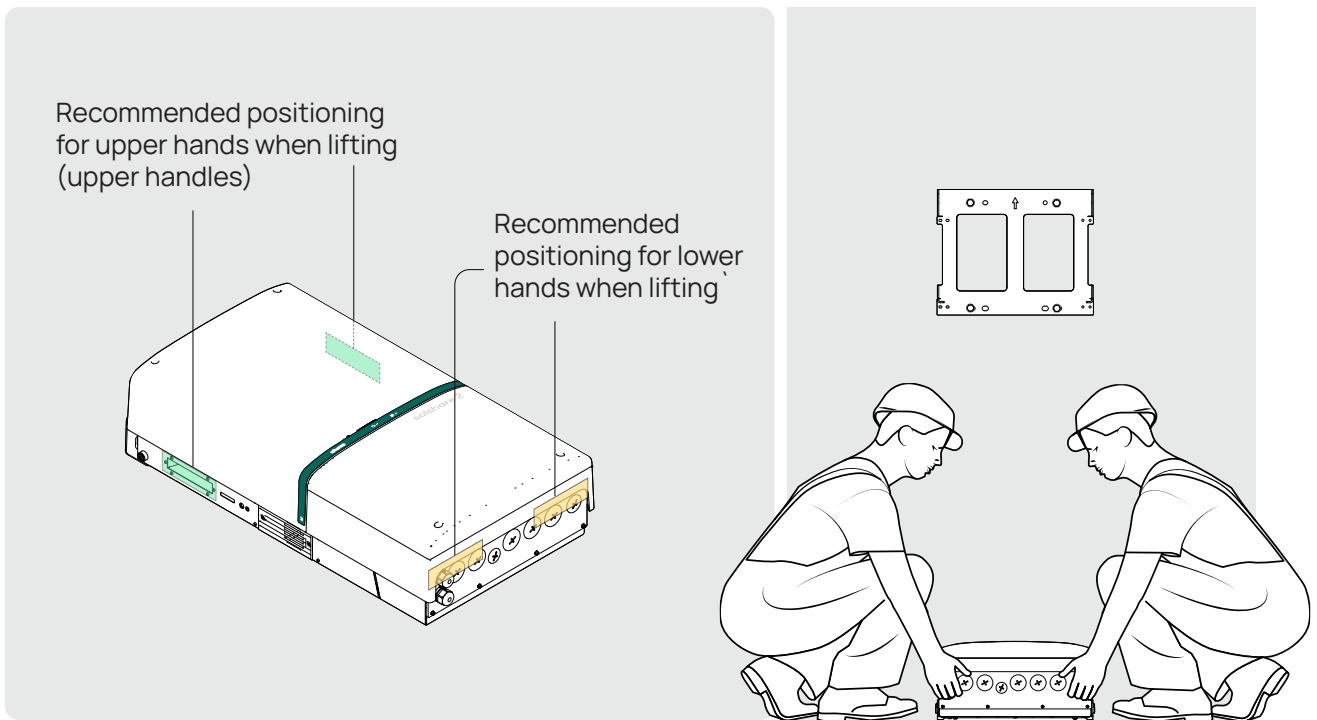
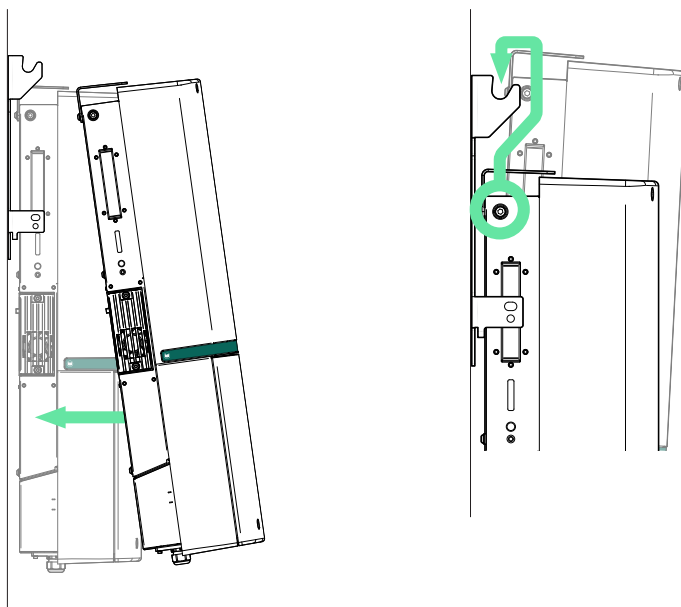
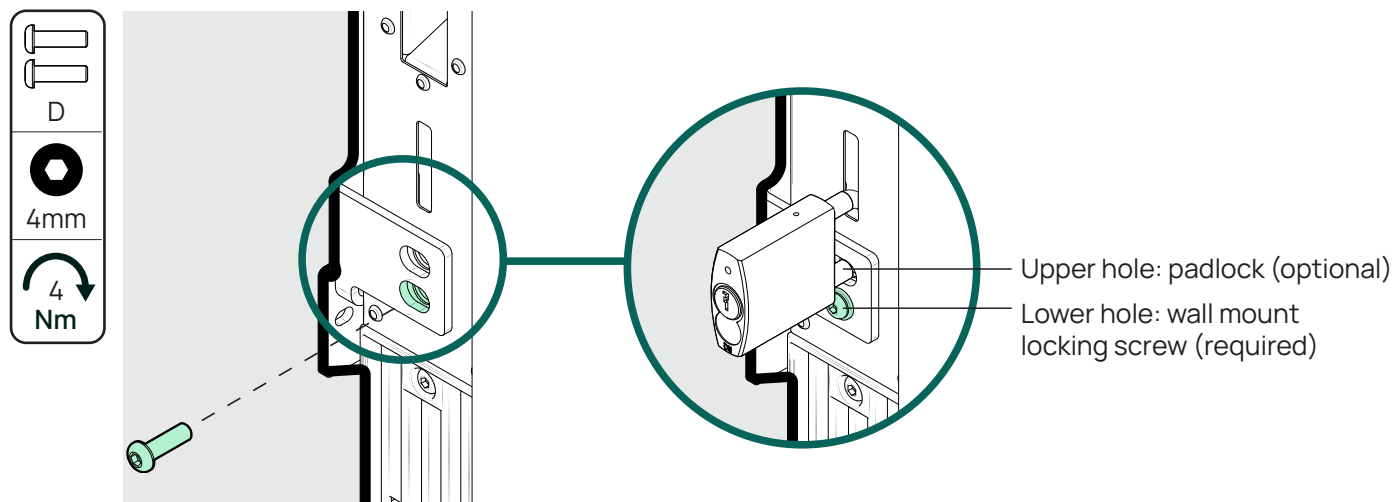

Figure 5-1: SolShare handles and recommended lift points

3 Lift SolShare on to the wall mount bracket with one person on each side of SolShare.



- 4 Use the wall mount locking screws provided with SolShare to secure SolShare to the wall mount bracket. A padlock can be used to lock SolShare in place.





6. Opening installation cover



WARNING

Risk of electric shock from live components

Contact with live components inside installation cover can cause injury or death. Ensure SolShare is de-energised prior to opening installation cover. See Section 13.2 for SolShare shutdown procedure.

1 To access SolShare's electrical and communications connections, open the installation cover.

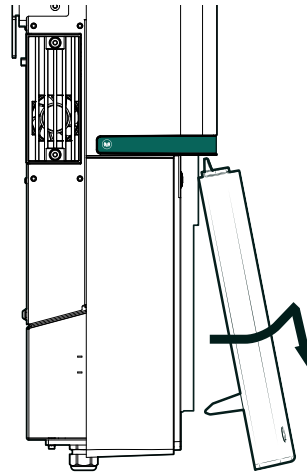
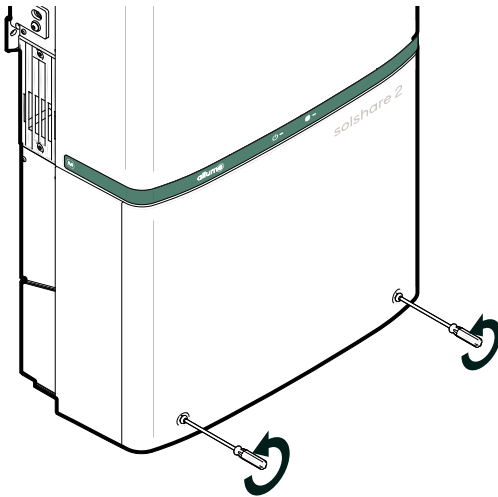

NOTICE

Visual check and ingress prevention

Inspect inside installation cover for damage before proceeding. Ensure installation cover and seals are kept free from damage. Ensure no dust, debris or water enters SolShare when installation cover is open.

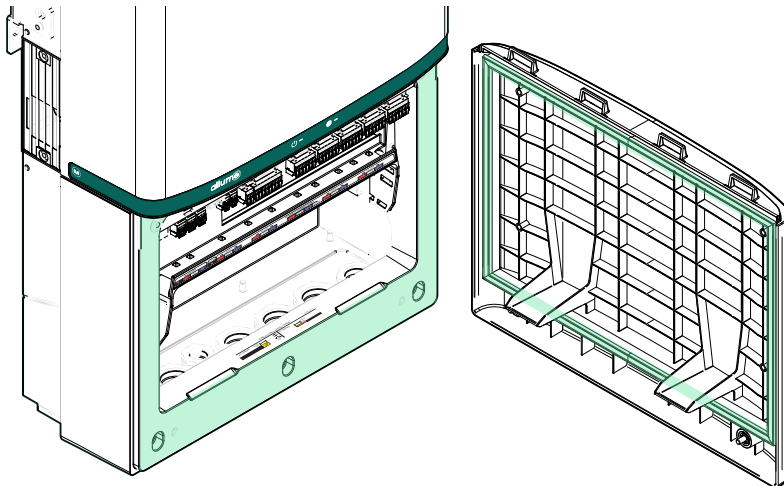

7. AC electrical connections



NOTICE

Unsuitable use of RCD, RCM, RCBO

Residual current devices (RCD), residual current monitoring (RCM), and residual current breakers with overcurrent protection (RCBO) must not be used for:

- MAIN SWITCHES (NORMAL)
- MAIN SWITCHES (INVERTER)
- SOLSHARE, AC ISOLATORS (GRID)

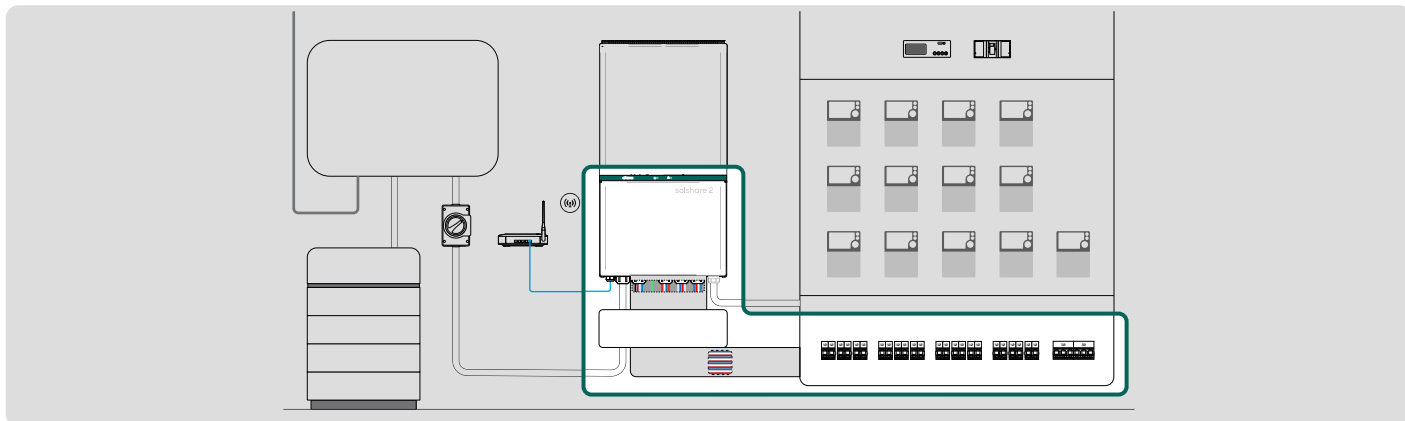

Figure 7-1: AC electrical connections between SolShare and switchboard

7.1. Maintenance isolator box



NOTICE

Inverter isolator

INVERTER ISOLATOR must provide suitable overcurrent protection for compliance with AS/NZS 4777.1:2024.



NOTICE

SolShare, AC Isolators (Grid)

Each SolShare tenancy connection must have a separate means of isolation externally and adjacent to SolShare for compliance with AS/NZS 4777.1:2024.

- 1 Install maintenance isolator box with SOLSHARE, AC ISOLATORS (GRID). Other terminations and switches, such as INVERTER ISOLATOR may also be included in maintenance isolator box. Maintenance isolator box can be installed directly below SolShare (observe required clearances in Section 4.5) for optimal cable entry into SolShare.

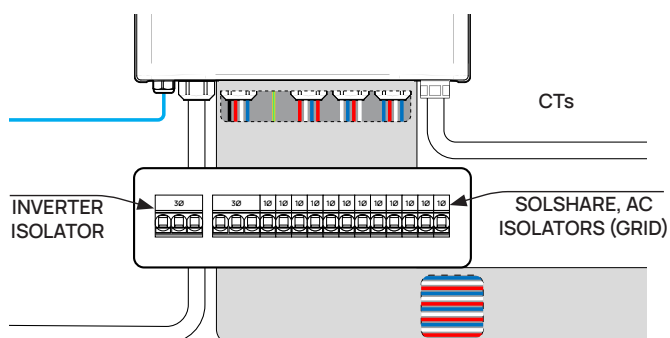



7.2. At SolShare

- 1 Open installation cover (see Section 6). Remove plugs from any holes on the bottom of SolShare that will be used for cable entry.

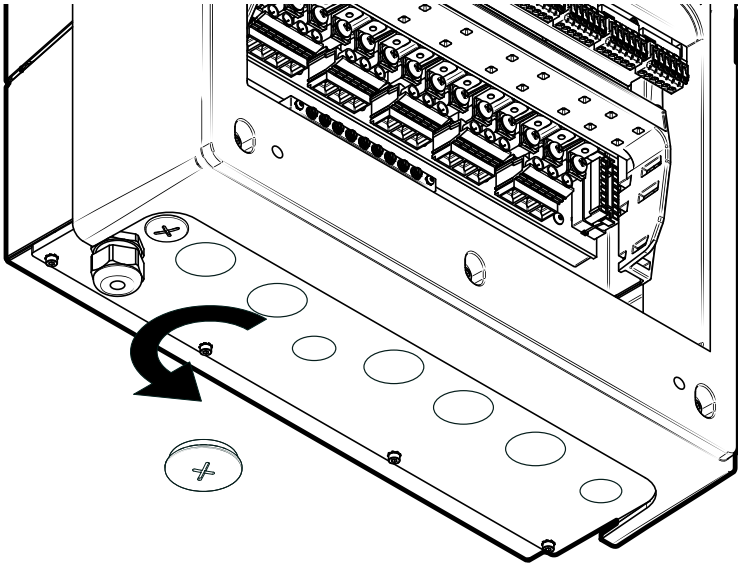

- 2 Install suitable glands/plugs for all cable entry holes. Refer to Table 2 for more information.



NOTICE

Maintain product IP rating

IP rating of SolShare must be maintained for dust and water protection. Suitable glands, plugs or other seals must be used at cable entry holes. Multi-hole glands with pips for unused holes must be used where individual conductors are used with SolShare.

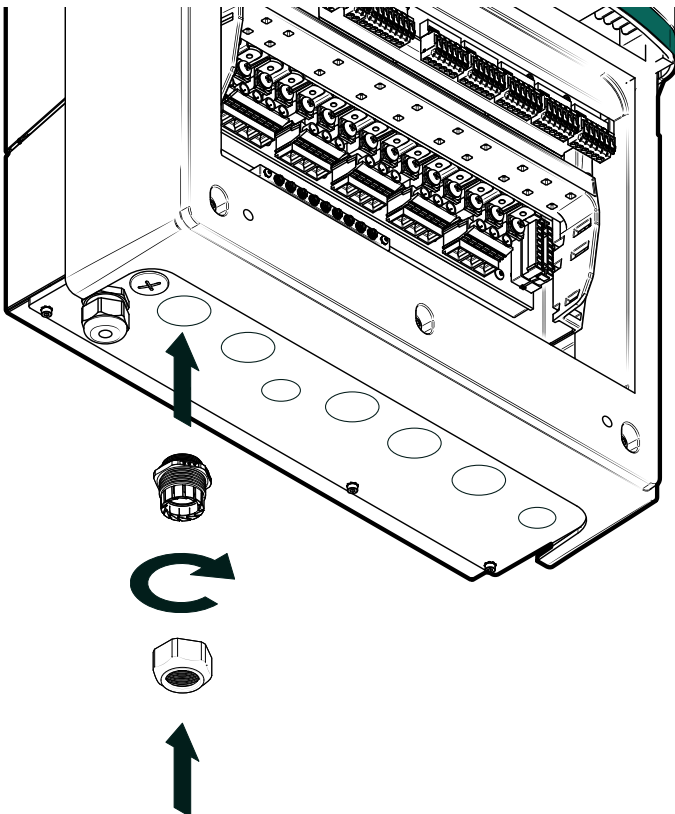

3 Terminate earth connections in Earth bar.

Terminate neutral connection into N as shown.

WARNING
Risk of electric shock

Contact with some parts of SolShare after energising SolShare without an earth connection may result in injury or death. SolShare must have an earth connection prior to energising.

NOTICE
Single neutral connection

SolShare requires a single connection to neutral. SolShare can provide an optional neutral connection to the inverter if required (see Step 4).

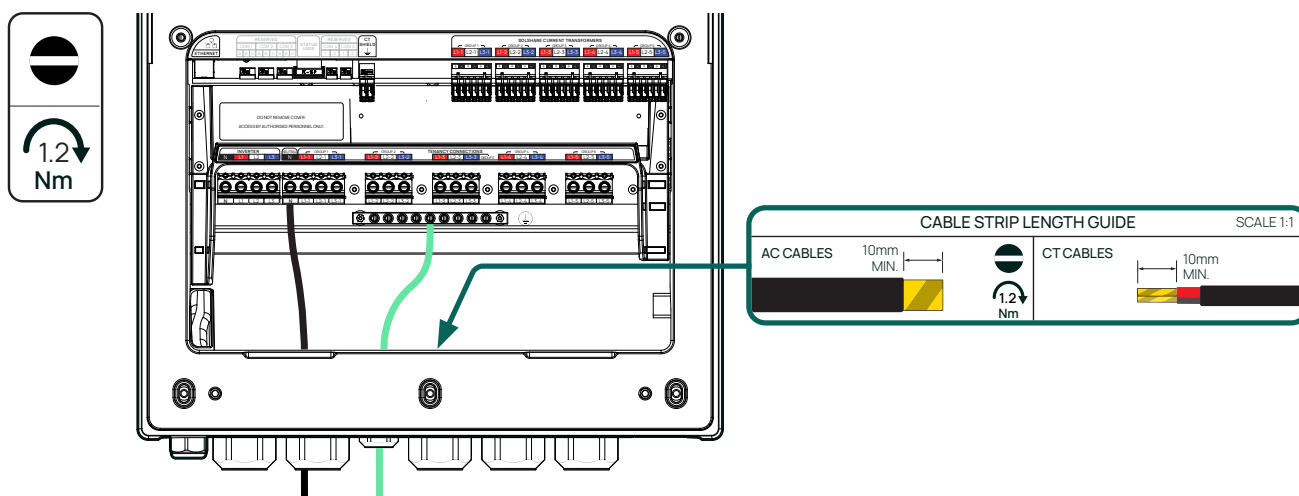

4 Terminate connections from inverter into INVERTER L1, L2, L3. Neutral connection to INVERTER N is optional. These connections may be made via the maintenance isolator box.

NOTICE
Maximum inverter current

Maximum current into SolShare at inverter input is: 50.9A per phase.

Exceeding this limit may cause damage to SolShare.

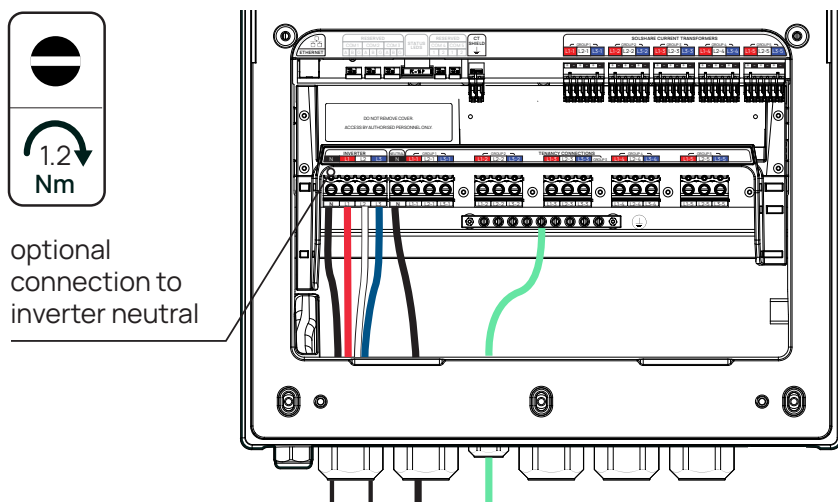



5 Terminate tenancy connections in SolShare from maintenance isolator box.



NOTICE Phase matching

The phase of each tenancy's solar connection from SolShare must correctly match the phase of that tenancy's supply from the grid.

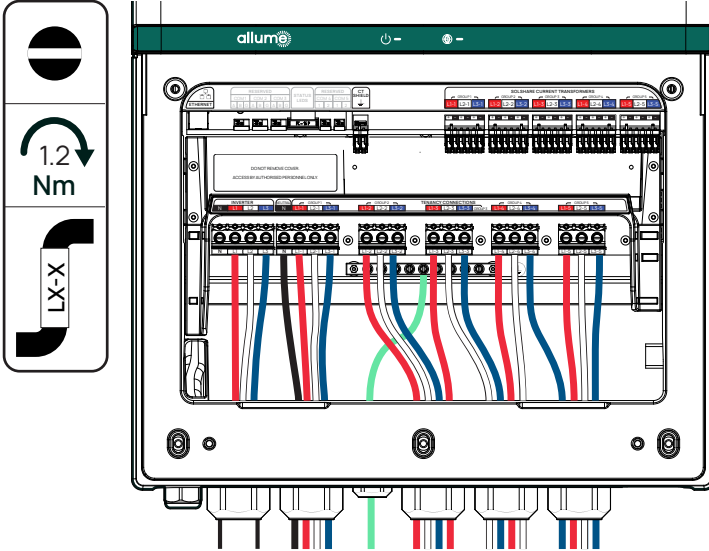

NOTICE 1 tenancy connection per phase

Each SolShare must have at least one active tenancy connection per phase.



TIP Tenancy connection cable sizing, cable type and overcurrent protection

At times, the full per-phase output of the inverter (up to 50.9A) connected to SolShare can be directed to one SolShare tenancy connection. All cables and overcurrent protection between SolShare tenancy connections and switchboard/s must be rated for any relevant regulations, and for total per-phase generation capacity of inverter/s.

Ensure cabling and enclosures comply with AS/NZS 3000:2018 3.9.8.2.1. E.g., cabling between SolShare and switchboard used for single-phase tenancies that form part of a multiple electrical installation shall not be installed within the same conduit or the same multi-core cable.



TIP Cable labelling

Each SolShare enables solar connections to up to 15 tenancies. All cables should be labelled correctly for effective troubleshooting and servicing of SolShare. Cable labels are provided with each SolShare.

7.3. At switchboard

- 1 Terminate connections from maintenance isolation box in the switchboard/s and label cables. Your project SLD should provide specific configuration information. The diagrams provided below show configurations for typical installations.

i TIP
Load-side solar point of connection (POC)

The solar point of connection (POC) for each tenancy must be on the load side of the tenancy's MAIN SWITCH (NORMAL) unless otherwise specified by your project single line diagram.

i TIP
MAIN SWITCH (INVERTER)

A MAIN SWITCH (INVERTER) must be installed for each tenancy.

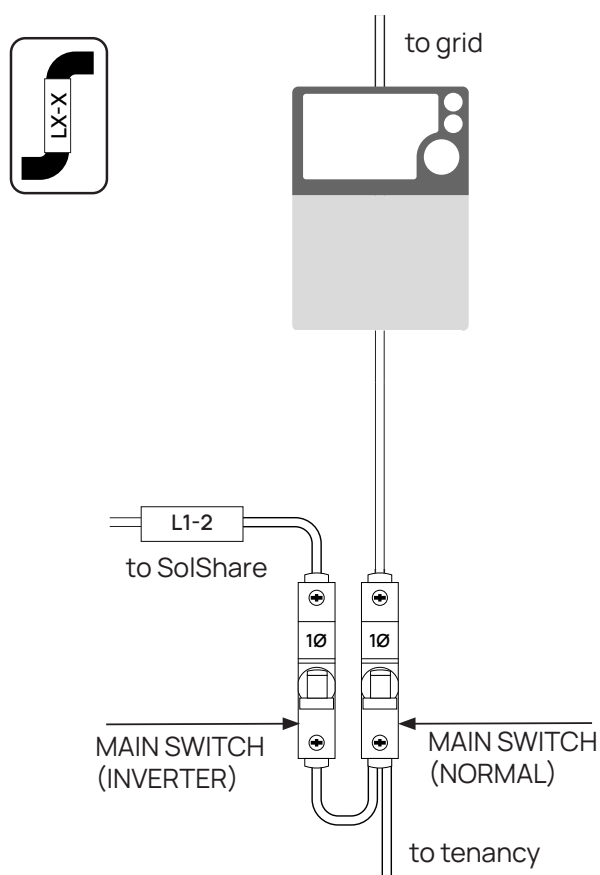



7.4. Compliance with emergency backstop mechanisms (EBMs)

7.4.1 What are EBMs?

EBMs allow the relevant Distribution Network Service Provider (DNSP) to remotely turn down or switch off solar exports during rare, low-demand events to prevent grid instability and blackouts.

Providing a means of compliant EBMs is, or soon will be, a legal requirement for many new and retrofit solar installations in states such as Victoria, South Australia, Queensland and New South Wales.

7.4.2 EBMs in installations with SolShare

The inverter (not SolShare) is responsible for providing EBM functionality in a shared solar installation.

All installations with SolShare that require EBMs must use EBM-compliant metering, typically measuring around the building's main incomer.

8. Current transformers

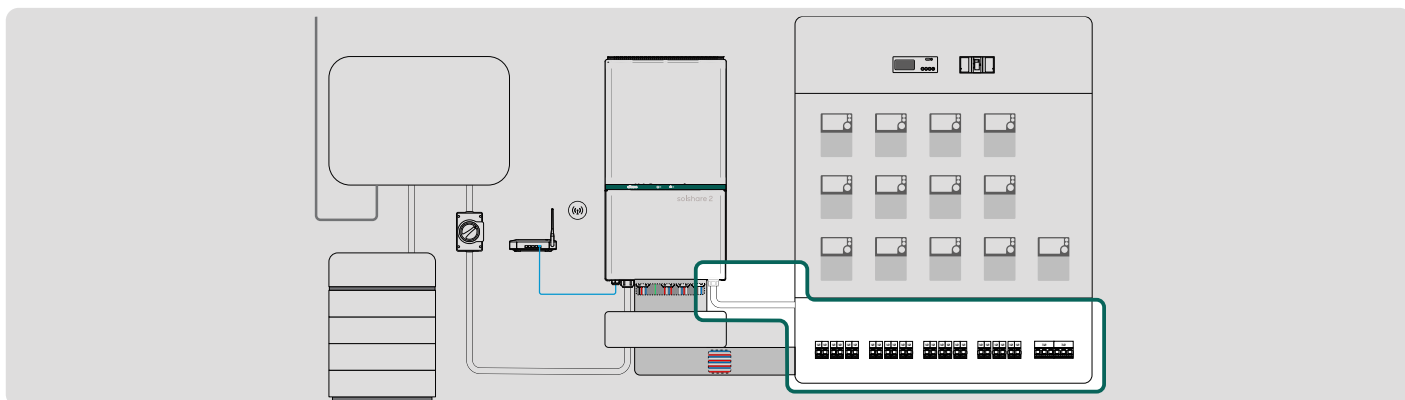

Figure 8-1: CT connections between SolShare and switchboard

Each SolShare is supplied with 15 x 120A clip-on split core current transformers (CTs) with locking pin. One CT must be installed for each SolShare tenancy connection used. Where more than one phase of a tenancy is connected to SolShare, one CT must be used per phase that SolShare is connected to.

Each CT is supplied with 10m of CT cable attached.



NOTICE
Extending CT cables

Extending CT cables is required where the cable run length between SolShare and the switchboard is more than 10m (see Section 8.3).



NOTICE
Use provided CTs

SolShare has been configured to operate with the CTs provided. Use only the CTs provided with SolShare.



8.1. At SolShare



NOTICE
Extending CT cables

Extending CT cables is required where the cable run length between SolShare and the switchboard is more than 10m (see Section 8.3).

1 Install suitable conduit adaptor for CT cable entry into SolShare. Refer to **Table 2** for more information.



NOTICE
Maintain product IP rating

IP rating of SolShare must be maintained. Suitable glands, plugs or other seals must be used at cable entry holes.

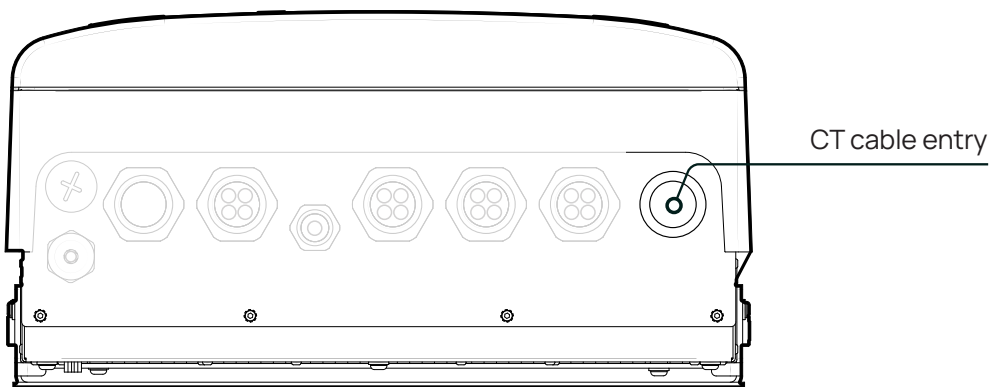

2 Terminate CT cables in SolShare and label cables.

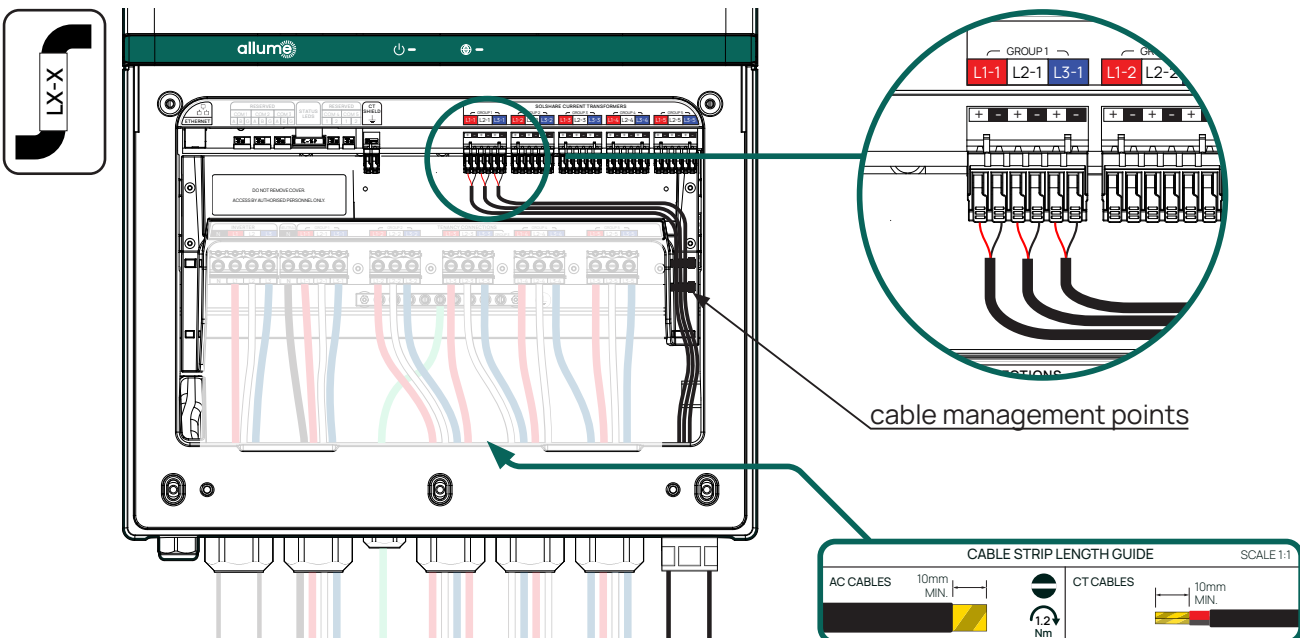

8.2. At switchboard

i NOTICE
Extending CT cables

Extending CT cables is required where the cable run length between SolShare and the switchboard is more than 10m (see Section 8.3).

- 1 Clip CTs in switchboard on the grid side of MAIN SWITCH (NORMAL) for each tenancy and label cables. A typical installation for a single phase tenancy is shown below.

i TIP
CT orientation

The arrow on the CT must be pointing away from the grid, and towards the MAIN SWITCH (NORMAL).

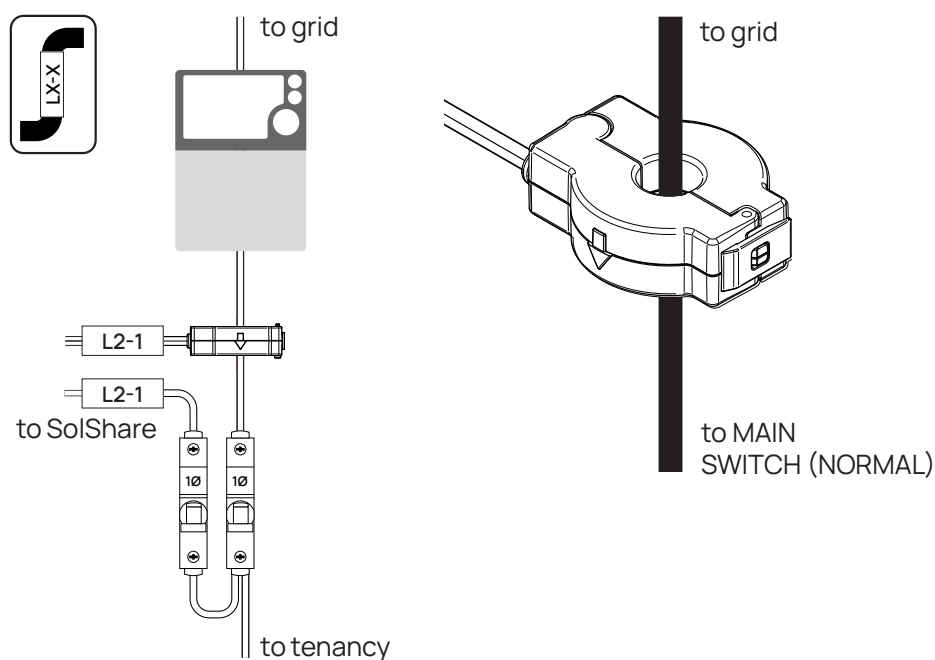

- 2 Insert the provided pin into each CT.

i NOTICE
CT pin

Ensure the pin is fully inserted into the CT to securely lock CT in place.

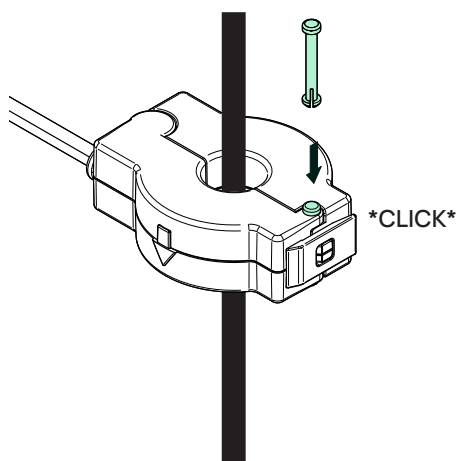



8.3. Extending CT cables

The requirements for CT extension cables and connectors are provided in **Table 3**.



NOTICE CT cable extensions

- CT cable extensions must use cables and connectors described in **Table 3**. Failure to do so may lead to incorrect CT readings, which may potentially slow down or prevent successful SolShare commissioning and operation.
- Ensure there is good electrical contact between original and extended CT cables.
- Ensure shielding is not compromised along the entire length of original and extended CT cables. Avoid the use of materials that could compromise shielding, such as metal cable ties.
- Label each end of the original and extended CT cables with the SolShare tenancy connection (e.g., L1-1). This will assist with efficient installation and troubleshooting.

1 Extend the CT cables.

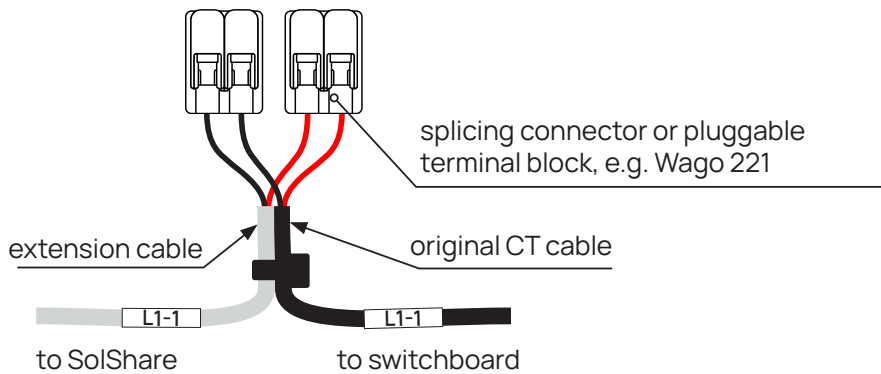

Figure 8-2: Extending CT cables

2 Earth the shielding of any extended CT cables.



NOTICE Overloading CT earthing terminals

Avoid overloading the SolShare's CT earthing terminals with too many cables. Use splicing connectors (e.g. Wago 221) to group CT extension shielding together. Use insulated cable from splicing connector/s to SolShare's CT earth terminals. Keep the length of exposed shielding to a minimum.

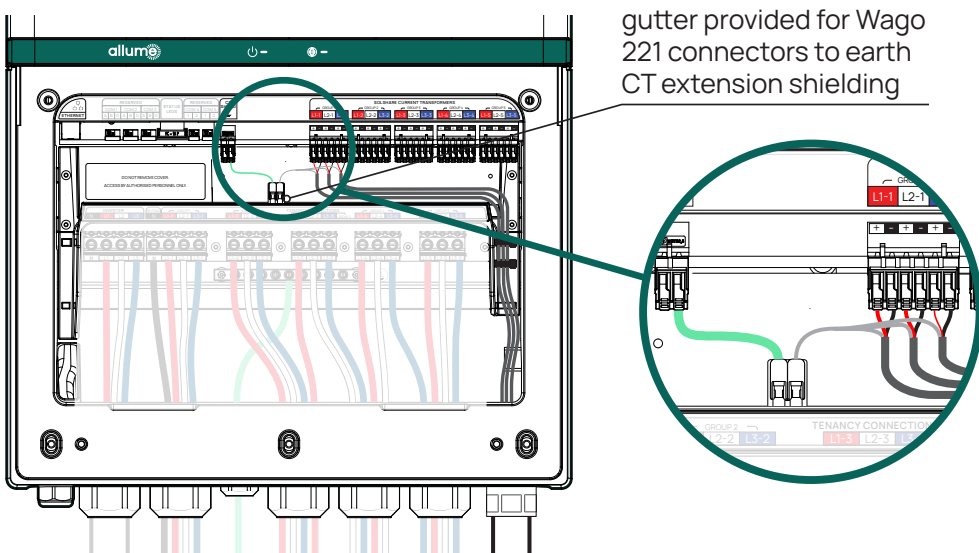

9. Internet and communications

SolShare must be connected to the internet for commissioning and ongoing operation.



NOTICE

Internet connection for warranty

It is a condition of warranty that SolShare is always connected to the internet throughout the warranty period.

SolShare supports two methods of internet communications:

- Recommended: Ethernet (see Section 9.1)
- Wi-Fi (see Section 9.2)

Only one method is required.

If SolShare is configured to connect to both Ethernet and Wi-Fi:

- The Ethernet connection will be prioritised.
- If the Ethernet connection does not have an internet connection then Wi-Fi connection will be attempted.

Figure 3-3 shows how SolShare communicates with other Allume services.

9.1. Ethernet

9.1.1 Ethernet Requirements

Plug type	RJ45
Cable	Ethernet cable, e.g., Cat5e/6/6a
Internet protocol	IPv4
Forward/open ports	TCP 80, 8883, 443 UDP 53, 123



9.1.2 Connecting SolShare via Ethernet

- 1 Insert the Ethernet cable into SolShare.



NOTICE

Communications cable gland

Use the supplied communications cable gland to maintain the IP rating of SolShare.

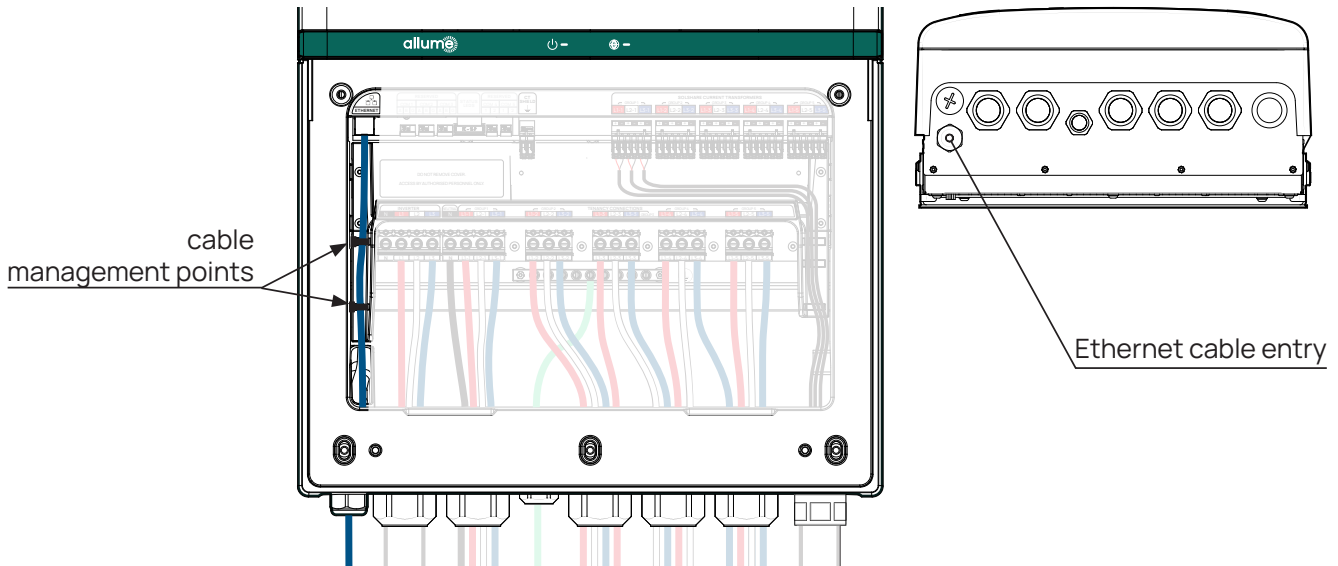

9.2. Wi-Fi

9.2.1 Wi-Fi network requirements

Network frequency	2.4GHz
Compatible protocols	802.11 b/g/n
Internet protocol	IPv4
Encryption	WPA2
Forward/open ports	TCP 80, 8883, 443 UDP 53, 123

9.2.2 Wi-Fi preparation

- 1 Prepare Wi-Fi network with powered router and active connection to the internet. See Section 12.2.2 for connecting SolShare to Wi-Fi.



NOTICE

Maintain IP rating

Ensure the provided pip for the Ethernet gland is in place to maintain IP rating of SolShare when Ethernet cable not in use.



TIP

Strong and stable Wi-Fi network

Ensure that the Wi-Fi network provides a strong and stable internet connection at SolShare's installation location.

10. Closing installation cover



WARNING

Risk of electric shock from live components

Contact with live components inside installation cover can cause injury or death. Ensure SolShare is de-energised prior to closing installation cover. See Section 13.2 for SolShare shutdown procedure.



NOTICE

Visual check and ingress prevention

Inspect the seal and seal surfaces inside the SolShare installation cover and ensure they are intact and free from debris. Ensure seals are clear of any cables or other obstructions.

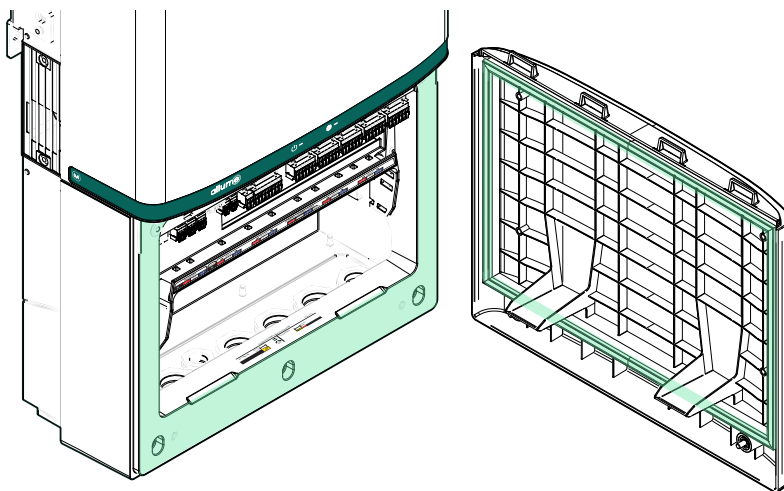

1 Replace the installation cover on to SolShare and tighten both screws.

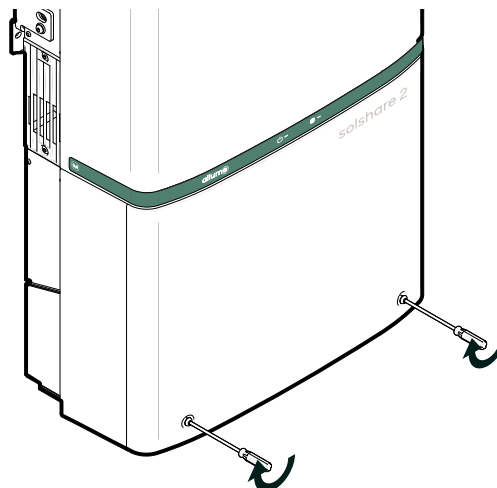
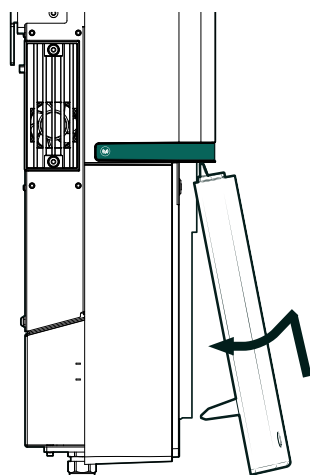



11. Site labelling and documentation

A label pack has been provided with SolShare that contains SolShare-specific labels required for compliance with AS/NZS 4777.1:2024. Additional industry-standard labels may also be required.

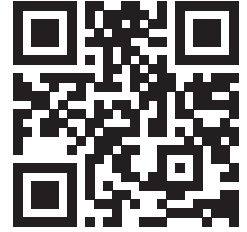

For Allume's most up-to-date labelling guidance follow the QR code or go to <https://hubs.li/Q03YQgv50>.



TIP Compliant labelling

Ensure that all labels applied at site (including those provided with SolShare) are compliant with the requirements of all relevant regulations and standards. Some labels provided with SolShare use standard naming conventions for switches onsite. Check for site-specific suitability of switch names used in these labels.



TIP Compliant site documentation

Ensure all required documentation for the installation location is kept at site for compliance with all relevant standards and regulations. For example, a minimum A3-sized SLD for compliance with AS/NZS 4777.1:2024.

A completed copy of the SolShare tenancy connections page (page supplied with SolShare) can be left at site to assist with future service and maintenance.

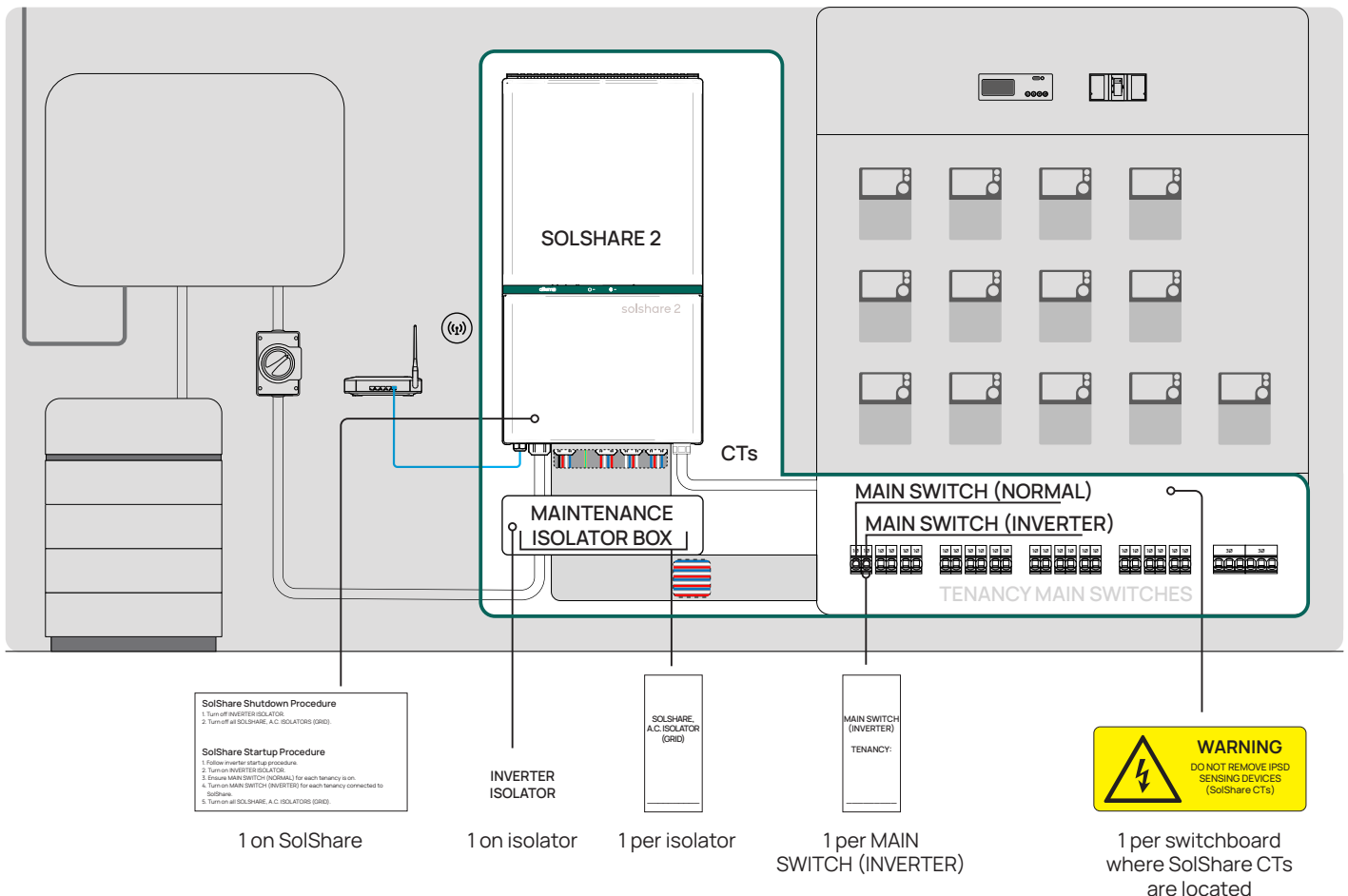

12. Commissioning

12.1. Pre-commissioning checks

Prior to commencing commissioning of SolShare, ensure that:

- SolShare has been installed such that it is accessible for operation, maintenance and service, and has the required clearances.
- All wiring connections are tight and secure.
- Nothing is left on the top of SolShare and all vents are clear.
- All unused holes utilise the supplied plugs or other suitable seals to maintain IP rating of SolShare.
- All covers are closed, including the installation cover (see Section 10).
- All required signage and labelling are suitably affixed and durable.
- Internet communications (Ethernet or Wi-Fi) are ready for connection.
- All electrical tests required for the installation location are undertaken, such as those required in AS/NZS 3000:2018, AS/NZS 4777.1:2024 and other relevant standards and regulations.

 **TIP**
SolShare commissioned before inverter

Commission the inverter in your installation AFTER SolShare has successfully completed commissioning.

12.2. Commissioning

 **WARNING**
Risk of electric shock from live components

Ensure the installation cover is closed on SolShare prior to energising (see Section 10).

1 Energise SolShare via all tenancy connections. Typically, this will involve:

- MAIN SWITCH (NORMAL) for each tenancy is ON.
- MAIN SWITCH (INVERTER) for each tenancy is ON.
- All SOLSHARE, AC ISOLATORS are ON.

SolShare status LED will show flashing yellow (prior to commissioning SolShare).



For additional information about LED states, see [Appendix B](#).

2 Connect SolShare to internet following Section 12.2.1 for Ethernet connections or Section 12.2.2 for Wi-Fi connections.



12.2.1 For Ethernet connections

- 1 Confirm the Internet/network LED is white.



For additional information about LED states, see **Appendix B**.

- 2 Open the SolShare Commissioning App on your device by scanning the QR code on the side of SolShare or navigating to <https://solcentre.allumeenergy.com/commissioning>. Sign in and follow the instructions to commission this SolShare.



TIP
Allume training and log-in

The person completing SolShare commissioning must have an up-to-date Allume training certificate of completion, and a SolShare Commissioning App log-in.

Once successfully commissioned, the SolShare status LED will flash white.



For additional information about LED states, see **Appendix B**.

For further assistance, contact Allume technical support on:

+61 3 7038 0686

support@allumeenergy.com.au

12.2.2 For Wi-Fi connections

- 1 Press and hold the  button on the left side of SolShare for 3 seconds to put SolShare in Wi-Fi access point mode. The Internet/network LED will flash blue.

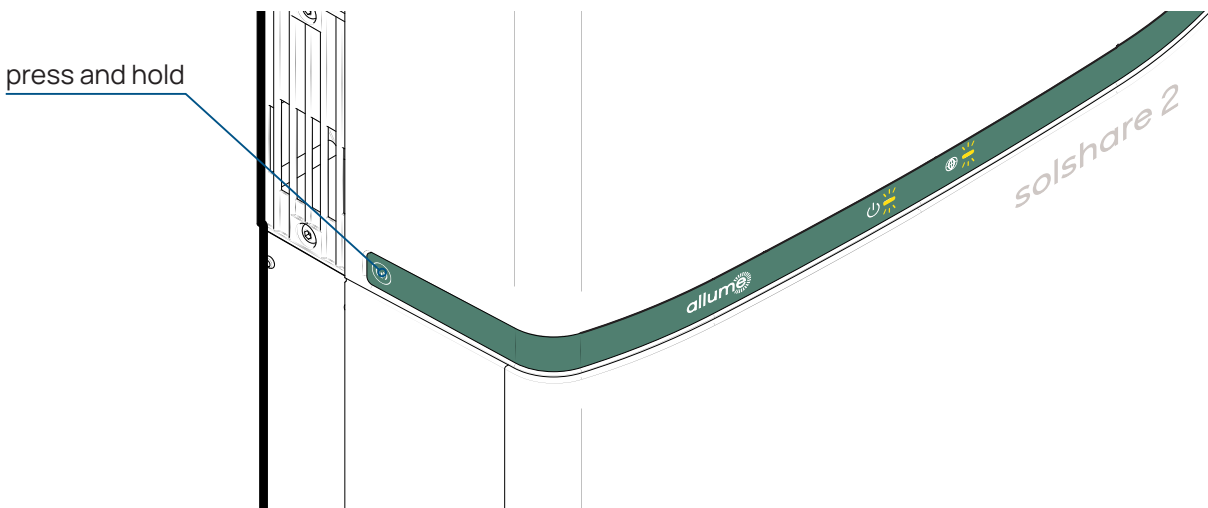

For additional information about LED states, see **Appendix B**.

- 2 Connect your device to SolShare's Wi-Fi network: **SolShare:[serial number]**. Continue even if your device indicates that this Wi-Fi network has no internet access.
- 3 On your device's internet browser, navigate to **http://192.168.4.1** (this may happen automatically).
- 4 Enter the Wi-Fi network details of the router. The Internet/network LED will show a series of states while attempting to establish a Wi-Fi and internet connection.
- 5 Confirm the Internet/network LED is white.



For additional information about LED states, see **Appendix B**.

i **TIP**
Wi-Fi access point inactivity

SolShare will exit Wi-Fi access point mode after 4 minutes if no device connects as per Step 2. It will exit Wi-Fi access point mode after 30 minutes if no Wi-Fi network connection has been made.

- 6 Open the SolShare Commissioning App on your device by scanning the QR code on the side of SolShare or navigating to <https://solcentre.allumeenergy.com/commissioning>. Sign in and follow the instructions to commission this SolShare.

i **TIP**
Allume training and log-in

The person completing SolShare commissioning must have an up-to-date Allume training certificate of completion, and a SolShare Commissioning App log-in.

Once successfully commissioned, the SolShare status LED will flash white.



For additional information about LED states, see **Appendix B**.

For further assistance, contact Allume technical support on:

 **+61 3 7038 0686**

 **support@allumeenergy.com.au**



12.3. Post-commissioning checks



NOTICE

Required electrical testing

Ensure all electrical tests required for the installation location are undertaken, such as those required in AS/NZS 3000:2018, AS/NZS 4777.1:2024 and other relevant standards and regulations.

After successfully commissioning SolShare, energise and commission inverter.



TIP

Inverter required for SolShare operation

Ongoing SolShare operation requires inverter to be operational. Ensure inverter is operational and there is a live connection between inverter and SolShare.

When the inverter is providing AC to SolShare (and all tenancy connections are able to receive solar, the SolShare status LED will be solid white.



For additional information about LED states, see **Appendix B**.

Sign into SolCentre to confirm the commissioned SolShare is operating as expected:

<https://solcentre.allumeenergy.com/>.

13. Startup and shutdown

13.1. Startup procedure



WARNING

Risk of electric shock from live components

Ensure the installation cover is closed on SolShare prior to energising (see Section 10).

Follow the SolShare startup procedure shown on SolShare (see Section 11). The following procedure is provided as a typical example where specific switch and isolator names may vary at your installation location.

- 1 Follow inverter startup procedure.
- 2 Turn on INVERTER ISOLATOR.
- 3 Ensure MAIN SWITCH (NORMAL) for each tenancy is on.
- 4 Turn on MAIN SWITCH (INVERTER) for each tenancy connected to SolShare.
- 5 Turn on all SOLSHARE, AC ISOLATORS (GRID).

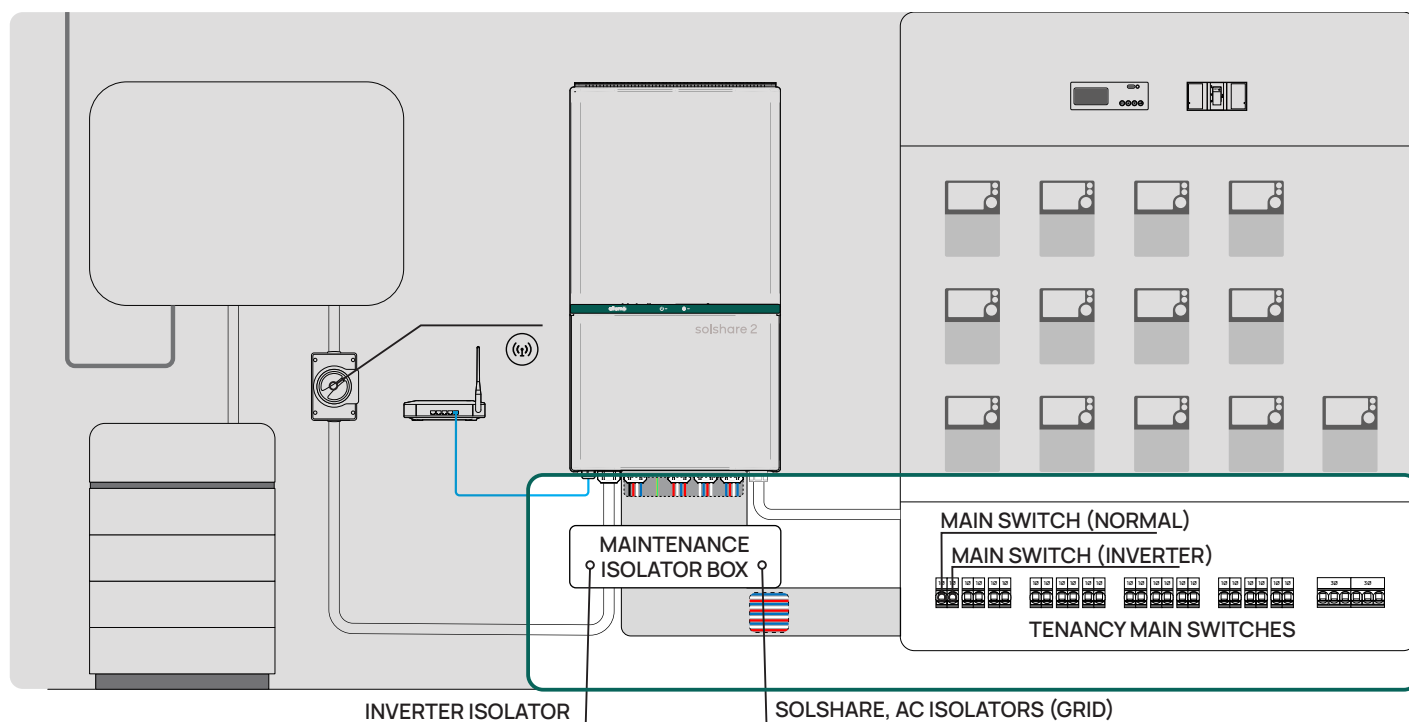

Figure 13-1: Typical location of switches and isolators used in SolShare's startup procedure

When SolShare has successfully been powered on (and SolShare and inverter are commissioned and operational), the SolShare status LED will be white:



For additional information about LED states, see Appendix B.



13.2. Shutdown procedure



WARNING

Risk of electric shock from live components

SolShare's status LEDs may not always reflect the powered state of SolShare. Always perform safety checks to ensure SolShare has successfully been de-energised after following SolShare shutdown procedure.

Follow the SolShare shutdown procedure shown on SolShare. The following procedure is provided as a typical example where specific switch and isolator names may vary at your installation location.

- 1 Turn off INVERTER ISOLATOR.
- 2 Turn off all SOLSHARE, AC ISOLATORS (GRID).

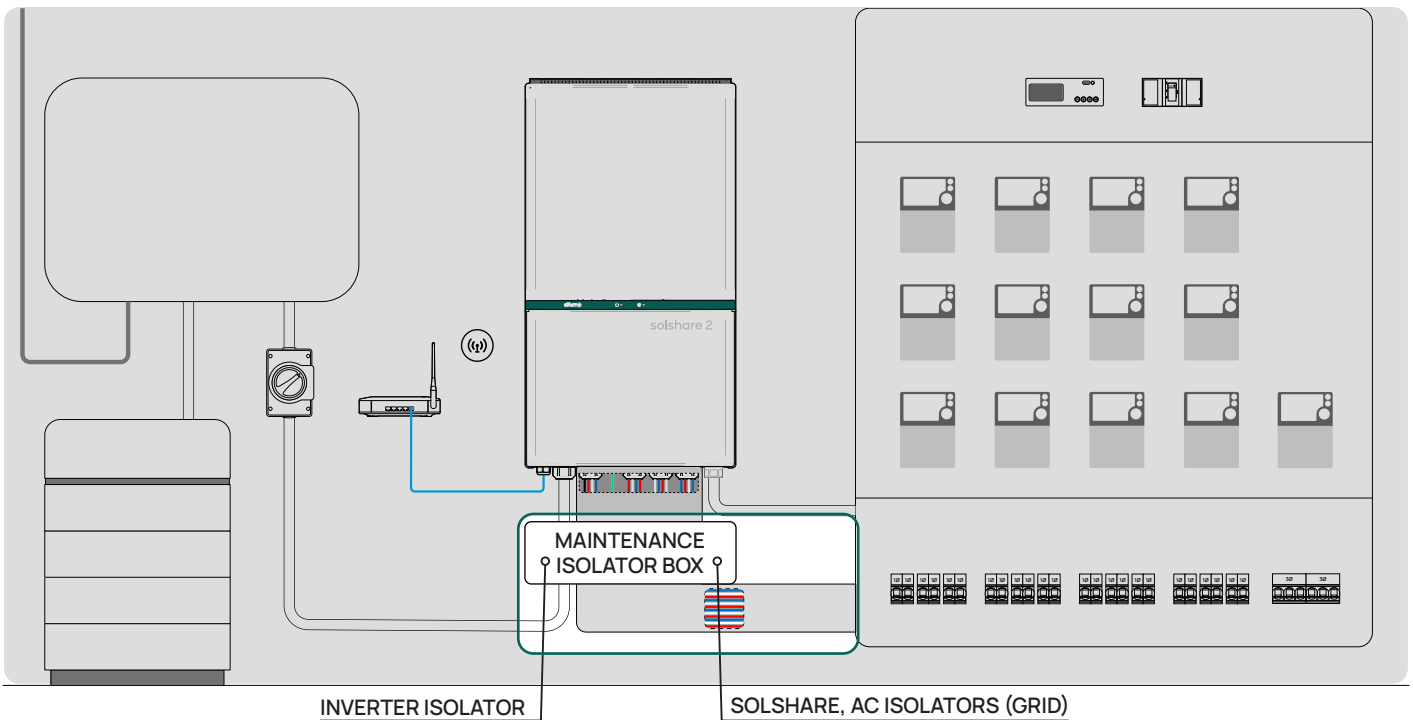

Figure 13-2: Typical location of isolators typically used in SolShare's shutdown procedure

When SolShare has successfully been powered off, both Status LEDs will be off.



For additional information about LED states, see [Appendix B](#).

14. Maintenance

The following maintenance tasks are recommended for maximum performance of SolShare. See **Figure 3-4** for more information on the location of SolShare components.



NOTICE Ingress prevention

Ensure no dust, debris or water enters SolShare when installation cover is open.

Recommended maintenance task	Frequency
Remove debris from vent and leaf guard on top face of SolShare (do not remove vent and leaf guard).	Every 12 months
Remove debris from fan inlets/outlets (do not remove fan guards).	Every 12 months
Wipe exterior surfaces of SolShare with a dry or lightly damp soft cloth to remove dust and stains. Avoid harsh substances. Do not use corrosive solvents, abrasive materials, or hard tools.	Every 12 months
Check SolShare is configured with the correct sharing mode (and allocations, if applicable) according to project designs.	After commissioning and recommended every 12 months thereafter



Appendix A: Technical information

Dimensions (H x W x D)	880mm x 480mm x 235mm
Weight	41kg
Weight (packaged)	52kg
AC connections (inverter and SolShare tenancy connections) rated voltage	230VAC (L-N)
AC connections inverter	400VAC (L-L)
AC connections (inverter and SolShare tenancy connections) voltage range	216-253VAC (L-N)
AC connections (inverter and SolShare tenancy connections) max. current per phase	50.9A
Rated current per phase (at 230V)	43.5A
Maximum output fault current (IEC62109-1, clause 4.4.4.5)	150A for 60ms (3-cycle RMS)
Maximum overcurrent protection (IEC62109-1, clause 4.4.4.7)	80A
Frequency range	47-53Hz
Rated max. power	30kVA (10kVA per phase)
Overvoltage category	III
Pollution degree	3
Protective class	I
Supply earthing system	TN-S
Environmental rating	Indoor and outdoor use (UV rated to UL 746C)
IP rating	IP65
Operating temperature range	-40°C to 50°C
Relative humidity range	4-100%
Maximum altitude	2000m
Customer interface	Allume SolCentre: https://solcentre.allumeenergy.com/
Firmware version	Viewable via SolCentre: <ul style="list-style-type: none">• Login to SolCentre• Select project• Navigate to 'configuration' tab• Select the specific SolShare• View: 'Software version'
SolShare shall provide only a supplementary supply to tenancy connections. SolShare is not suitable for providing other functionality, such as backup.	

Appendix B: Status LED states

Indicator	LED state	Meaning	Recommended action	
SolShare status 		Solid White	Normal SolShare operation	None.
		White flash	Normal SolShare operation, solar not available to some or all tenancy connections	<ul style="list-style-type: none"> Check inverter status - solar may be unavailable due to time of day (e.g., night) or inverter may have a fault. Check SOLSHARE, A.C. ISOLATORS (GRID), MAIN SWITCH (INVERTER), MAIN SWITCH (NORMAL) for each tenancy and turn on if safe to do so. Consult SolCentre for more information.
		Solid yellow	Error: limited SolShare operation	Consult SolCentre for more information.
		Solid red	Error: SolShare not in operation	Consult SolCentre for more information.
		Yellow flash 1 flash every 2 seconds	Normal SolShare operation: Un-commissioned	Scan QR code on side of SolShare to launch SolShare Commissioning App.
		Green flash	Normal SolShare operation: Undergoing commissioning	None - monitor SolShare Commissioning App for further information.
		Rapid yellow flash 3 flashes every 2 seconds	Error: Error during commissioning	Consult SolShare Commissioning App for troubleshooting guidance.
Internet/ network 		Solid white	SolShare connected to internet	None.
		Blue flash 1 flash every 2 seconds	SolShare in Wi-Fi access point mode and is awaiting information to connect to a Wi-Fi network	See instructions in Section 12.2.2 to connect SolShare to Wi-Fi.
		Rapid blue flash 3 flashes every 2 seconds	SolShare attempting connection to Wi-Fi network	None.
		Yellow flash	SolShare connected to Wi-Fi network but Wi-Fi network has no internet connection.	See Section 9 for network requirements and check internet access of Wi-Fi network.
		Red flash	Recent Wi-Fi connection failed	Check Wi-Fi details and ensure Wi-Fi network is available at SolShare location. Repeat instructions in Section 12.2.2 to connect SolShare to Wi-Fi. NOTE: LED will transition to solid yellow after 60 seconds.
		Solid yellow	SolShare not connected to internet and/or could not connect to Wi-Fi network	See Section 9 for network requirements. Wi-Fi: Check Wi-Fi details and ensure Wi-Fi network is available at SolShare location. Repeat instructions in Section 12.2.2 to connect SolShare to Wi-Fi.
SolShare status and Internet/ network 		Solid red	Error: SolShare not in operation	Consult SolCentre for more information.



this page is intentionally left blank

this page is intentionally left blank

This manual is intended for installations in **Australia and New Zealand**.
Specifications are subject to changes without advanced notification.

For the most up to date documentation,
visit allumeenergy.com/au/resource-library

Allume Energy
allumeenergy.com/au
info@allumeenergy.com
AUS: +61 3 9427 0005